

Product Information Sheet

EQUIPMENT GROUND JUMPER KIT

Use the Equipment Ground Jumper Kit with the Vertical Rack Busbar Kit or Rack Ground Bar Kit to bond rack-mount equipment. The Equipment Ground Jumper Kit includes a 24" long insulated green/yellow stripe #6 AWG ground conductor with a Slotted Compression Lug on one end and a 90° Slotted Compression Lug on the other end. The 90° Slotted Lug attaches to the busbar or ground bar allowing easy alignment with equipment. The Slotted Compression Lug attaches to equipment. The kit includes an abrasive pad, antioxidant joint compound and two installation screws to prepare and secure the jumper to the busbar or ground bar. The installer must provide installation hardware for the lug that attaches to equipment.

- Each kit includes one 24"L insulated ground jumper with attached lugs, two plated installation screws, an abrasive pad and joint compound
- The lugs are made from electroplated tinned copper and have two mounting holes spaced .5" to .625" apart that accept 1/4" screws
- Made with UL Listed components

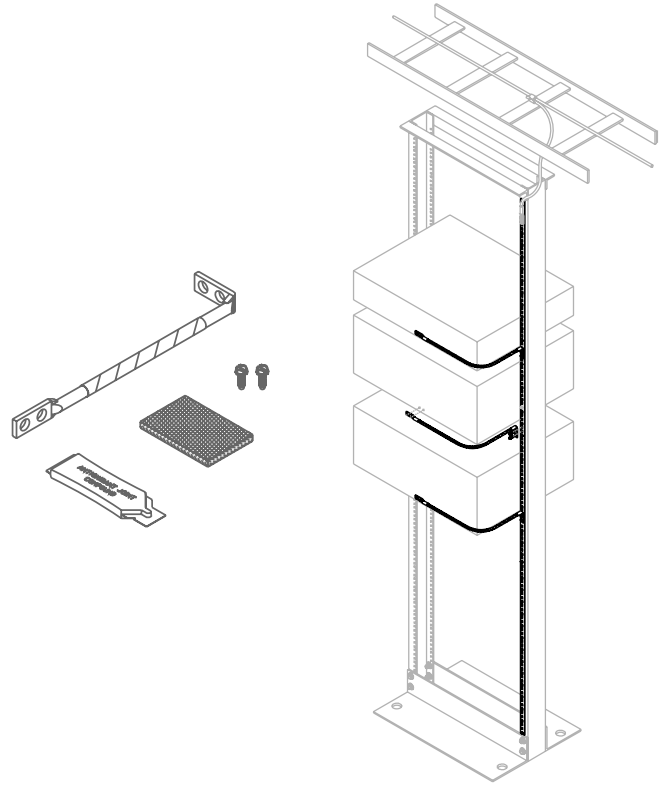

Part Number	Description	Shipping Weight
40159-010	Equipment Ground Jumper Kit	2 lb (0.9 kg)

800-834-4969 in U.S. & Canada • www.chatsworth.com



CHATSWORTH PRODUCTS, INC.

©2008 Chatsworth Products, Inc. All rights reserved. CPI, Saf-T-Grip, Seismic Frame, SlimFrame and MegaFrame are federally registered trademarks of Chatsworth Products, Inc. CPI Passive Cooling, Cube-iT Plus, Evolution, Simply Efficient, TeraFrame and QuadraRack are trademarks of Chatsworth Products, Inc. All other trademarks belong to their respective companies. 07/08