

ThinLine II Wall-Mount Cabinet

The space-saving ThinLine II safely secures 19" EIA rack-mount network equipment with minimal intrusion into the room—perfect for tight areas and high-traffic places such as classrooms and retail stores.

The ThinLine II maximizes interior space using a distinctive equipment mounting rail system. Individual rails can be easily rotated for horizontal or vertical mounting and then bolted into place, making patch panel punchdown easier. The cabinet can hold a server, switch, horizontal cable manager, patch panel, fiber service loop and fiber-optic patch panel — with room to accommodate additional mounting needs.

An easy-to-remove top panel slides in and out of position (without tools) using a spring button release. In addition, the 26"H (660 mm) cabinet can be mounted so that the removable "top" panel becomes a side panel.

A 4" x 6" (100 mm x 150 mm) opening in the rear of the cabinet and knockouts sized 3/4" and 1-1/2" allow cable entry and exit. Multiple cable tie-down points in rear panel and included Saf-T-Grip® straps secure cables safely.

- Door features rounded edges and corners and can be mounted to open from either right or left
- Removable top panel provides direct access to equipment without disturbing other devices
- Multiple pairs of mounting rails support equipment in vertical, horizontal or angled orientation
- Multiple sets of knockouts allow flexibility in cable organization
- Louvers and fan accessory provide ventilation
- Cabinet includes a 2" x 4" (50 mm x 100 mm) junction box to hold an optional surge-suppressed duplex outlet, eliminating the need for a power strip
- Made of steel
- Ships assembled with extra mounting rails and mounting hardware
- Static load rating is 100 lb (45.4 kg)



ORDERING INFORMATION

Part Number	Description	Shipping Weight lb (kg)
13050-X11	26"H x 26"W x 5"D, 2U (660 mm x 660 mm x 130 mm)	47 (21.3)
13050-X12	26"H x 26"W x 8.5"D, 4U (660 mm x 660 mm x 216 mm)	54 (24.5)
13050-X13	26"H x 26"W x 12"D, 6U (660 mm x 660 mm x 300 mm)	60 (27.2)
13050-X21	36"H x 26"W x 5"D, 2U (910 mm x 660 mm x 130 mm)	60 (27.2)
13050-X22	36"H x 26"W x 8.5"D, 4U (910 mm x 660 mm x 216 mm)	68 (30.8)
13050-X23	36"H x 26"W x 12"D, 6U (910 mm x 660 mm x 300 mm)	76 (34.5)

X=Color: 1=Gray, 2=Computer Beige, 7=Black

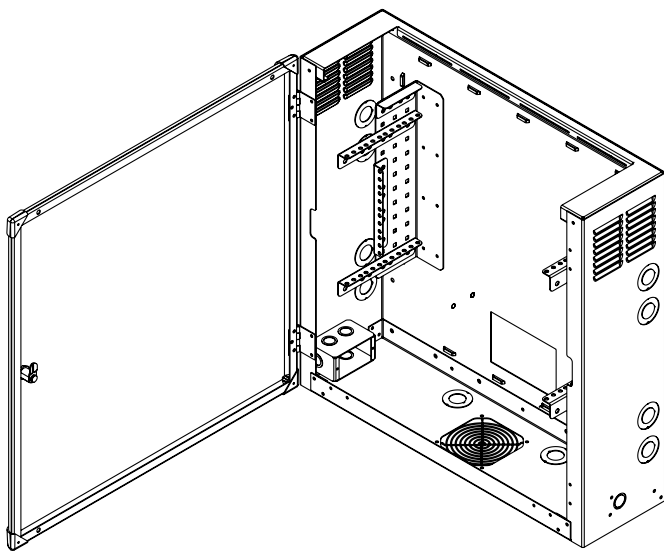

For product CSI Specs, visit the Support & Downloads page on www.chatsworth.com.

US & Canada

+1-800-834-4969
 Toronto, Ontario, Canada
 +905-850-7770
chatsworth.com
techsupport@chatsworth.com

Latin America

+52-55-5203-7525
 Toll Free within Mexico
 01-800-01-7592
chatsworth.com.co

Europe

+44-1628-524-834
chatsworthproducts.co.uk

Middle East & Africa

Dubai, UAE
 +971-4-2602125
chatsworth.ae

Asia Pacific

+86 21 6880-0266
chatsworth.com.cn



CHATSWORTH
 PRODUCTS