

# Product Cut Sheet

## FLUSH-MOUNT KEYBOARD TRAY

Provides retractable rack mounting tray for most keyboards up to 8.5" deep. Mounting hardware not included.

- Made of sturdy .090 aluminum
- Extends 8" giving full access to keyboard, retracts when not in use
- 19" version holds up to 16.1" wide keyboards
- Sold individually
- U.S. Patent No. D.391,084

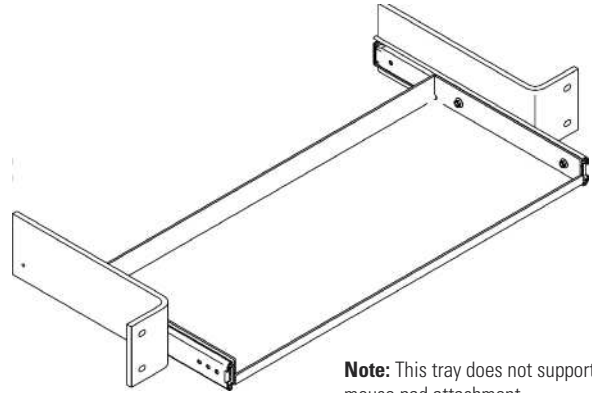

**Note:** This tray does not support the mouse pad attachment.

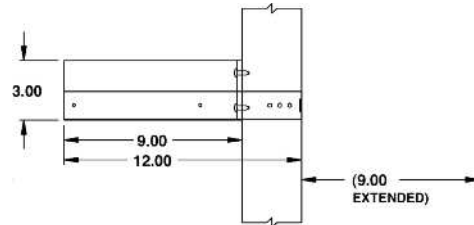

Part Number	Description	Shipping Weight lb (kg)
12717-X19	Flush-Mount Keyboard Tray, For 19" Rack	8 (3.6)

19" rack tray must use small footprint keyboard.  
X=color: 1=Gray, 2=Computer Beige, 5=Clear, 7=Black, E=Glacier White.

800-834-4969 in U.S. & Canada • [www.chatsworth.com](http://www.chatsworth.com)



©2013 Chatsworth Products, Inc. All rights reserved. CPI, CPI Passive Cooling, GlobalFrame, MegaFrame, Saf-T-Grip, Seismic Frame, SlimFrame, TeraFrame, Cube-IT Plus, Evolution, OnTrac, Velocity and QuadraRack are federally registered trademarks of Chatsworth Products. eConnect and Simply Efficient are trademarks of Chatsworth Products. All other trademarks belong to their respective companies. 6/13