

Equipment Support Bracket

Equipment Support Bracket mounts to the rear rails to provide additional support and safety for deep or heavy electronic equipment panels and equipment mounted on CPI racks or cabinets.

- Supports equipment weighing up to 60 lbs (27.2 kg)
- Made of Strong, lightweight aluminum
- Overall depth is 13" (330 mm); chassis support lip is 1.5" W (38 mm)
- Fits all EIA Standard, hole-patterned equipment mounting rails, cabinets and four-post racks
- Eliminates equipment deflection caused by cantilevered mounting

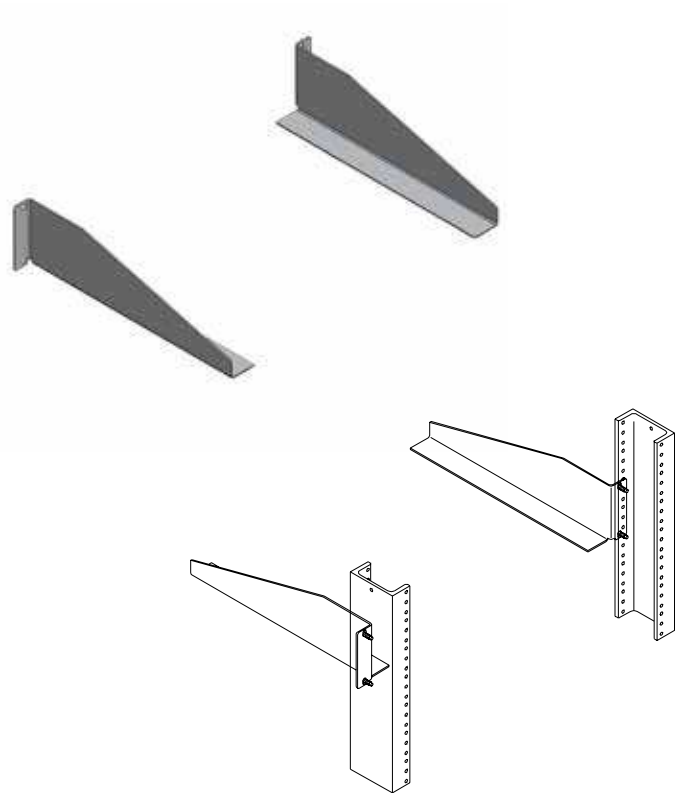

ORDERING INFORMATION

Part Number	Description	Shipping Weight lb (kg)
12312-X01	Equipment Support Bracket, Pair	2 (0.9)

Notes: X=color: 1=Gray, 2=Computer Beige, 5=Clear, 7=Black, E=Glacier White.
Sold in pairs. Attachment hardware not included.

For product CSI Specs, visit the Support & Downloads page on www.chatsworth.com.

US & Canada

+1-800-834-4969
Toronto, Ontario, Canada
+905-850-7770
chatsworth.com
techsupport@chatsworth.com

Latin America

+52-55-5203-7525
Toll Free within Mexico
01-800-01-7592
chatsworth.com.co

Europe

+44-1628-524-834
chatsworthproducts.co.uk

Middle East & Africa

Dubai, UAE
+971-4-2602125
chatsworth.ae

Asia Pacific

+86 21 6880-0266
chatsworth.com.cn



CHATSWORTH
PRODUCTS