

Product Cut Sheet

LARGE HORIZONTAL RING PANEL

Used to organize horizontal cable runs. Large 2.8"H (71 mm) by 6"W (150 mm) heavy duty aluminum rings with rounded edges protect cable sheaths and will not bind during installation. Rings are bolted onto panels, so they can be added or removed as needed. 19" and 23" wide rack panel options come pre-assembled with seven equally spaced rings.

- 2.8"H x 6"W (71 mm x 150 mm) heavy duty aluminum rings
- Rings can be added or removed as needed
- Installation hardware not included
- Shipping weight approximately 5 lb (2.3 kg)

Slip-On Cover, Ring Panel

The Slip-On Cover is used on the Large Horizontal Ring Panel, P/N 11564-XXX. Sold individually

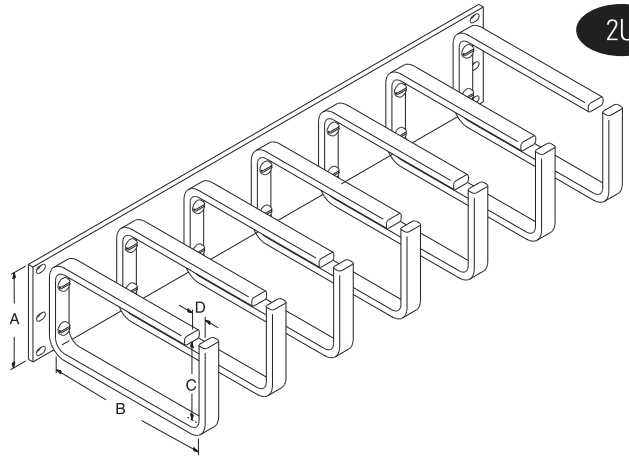

- A 3.47" (88.1 mm)
- B 6.00" (152.4 mm)
- C 2.85" (72.4 mm)
- D 0.56" (14.2 mm)

Part Number		Description
19"	23"	
11564-X19	11564-X23	Ring Panel

X=color: 1=Gray, 2=Computer Beige, 5=Clear, 7=Black, E=Glacier White.

Part Number	Description	Shipping Weight lb (kg)
11764-X19	Slip-On Cover, 19"W, for 11564-X19	2 (0.9)
11764-X23	Slip-On Cover, 23"W, for 11564-X23	2 (0.9)

X=color: 1=Gray, 2=Computer Beige, 5=Clear, 7=Black, E=Glacier White.

800-834-4969 in U.S. & Canada • www.chatsworth.com



CHATSWORTH PRODUCTS

©2013 Chatsworth Products, Inc. All rights reserved. CPI, CPI Passive Cooling, GlobalFrame, MegaFrame, Saf-T-Grip, Seismic Frame, SlimFrame, TeraFrame, Cube-iT Plus, Evolution, OnTrac, Velocity and QuadraRack are federally registered trademarks of Chatsworth Products. eConnect and Simply Efficient are trademarks of Chatsworth Products. All other trademarks belong to their respective companies. 07/13