

# Product Cut Sheet

## TRIANGULAR SUPPORT BRACKET, ALUMINUM

Triangular Support Bracket provides wall support for Cable Runway. Made of 1/4" x 2" (6.4 mm x 50 mm) aluminum bar. Load rating is 100 lb (45.4 kg).

**Kit consists of:**

- (1) triangular bracket
- (2) 5/16-18 x 2 1/4" J-bolts
- (2) 5/16-18 hex nuts & 5/16 lock washers

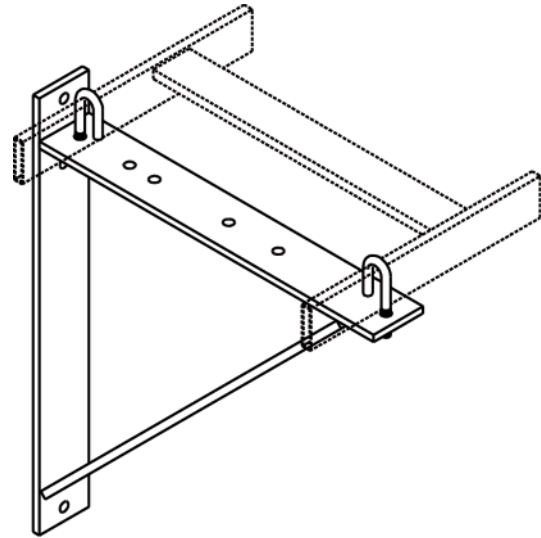

Part Number	Runway Widths in (mm)	Shipping Weight lb (kg)
11312-X06	4-6 (100 - 150)	2 (0.9)
11312-X12	6-12 (150 - 300)	3 (1.4)
11312-X18	12-18 (300 - 460)	3 (1.4)

*X=*color: 1=Gray, 2=Computer Beige, 7=Black, E=Glacier White

800-834-4969 in U.S. & Canada • [www.chatsworth.com](http://www.chatsworth.com)



**CHATSWORTH PRODUCTS**

©2013 Chatsworth Products, Inc. All rights reserved. CPI, CPI Passive Cooling, GlobalFrame, MegaFrame, Saf-T-Grip, Seismic Frame, SlimFrame, TeraFrame, Cube-IT Plus, Evolution, OnTrac, Velocity and QuadraRack are federally registered trademarks of Chatsworth Products. eConnect and Simply Efficient are trademarks of Chatsworth Products. All other trademarks belong to their respective companies. 6/13