

Product Cut Sheet

DOUBLE-SIDED VENTED SHELF

Convenient for mounting any equipment requiring bottom ventilation, air-flow perforations for increased airflow around components. Mounting hardware not included. 19" version holds equipment up to 17.75"W x 21.5"D (450.9 mm x 546.0 mm), 23" version holds equipment up to 21.75"W x 21.5"D (552.5 mm x 546.0 mm). Made of strong, lightweight aluminum; supports up to 100 lb (45.4 kg).

Part Number	Description	Shipping Weight lb (kg)
11231-X19	Double-Side Vented Shelf, For 19" Rack	8 (3.6)
11232-X23	Double-Side Vented Shelf, For 23" Rack	9 (4.1)

X=color: 1=Gray, 2=Computer Beige, 5=Clear, 7=Black, E=Glacier White

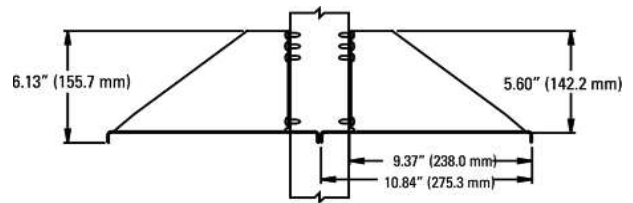
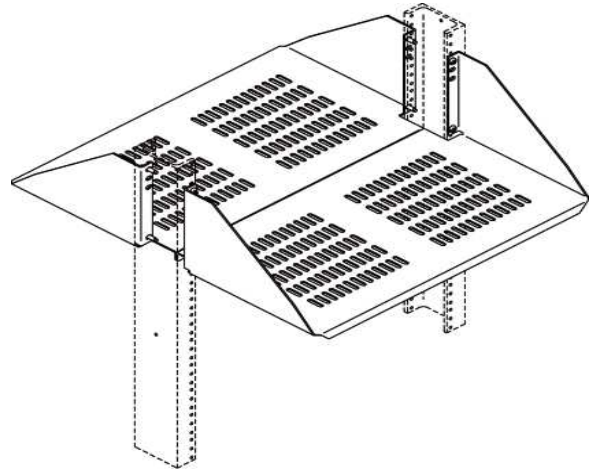

800-834-4969 in U.S. & Canada • www.chatsworth.com



©2013 Chatsworth Products, Inc. All rights reserved. CPI, CPI Passive Cooling, GlobalFrame, MegaFrame, Saf-T-Grip, Seismic Frame, SlimFrame, TeraFrame, Cube-IT Plus, Evolution, OnTrac, Velocity and QuadraRack are federally registered trademarks of Chatsworth Products. eConnect and Simply Efficient are trademarks of Chatsworth Products. All other trademarks belong to their respective companies. 6/13