

Product Cut Sheet

CABLE RUNWAY RADIUS BEND

Creates a gradual bend for cascading cable runs.

- Made of lightweight 1-1/2" x 3/8" (38.1 mm x 9.53 mm) tubular steel
- Three cross members welded at approximately 23 degree increments
- Outside/Inside is determined by welding cross members closer to cable side

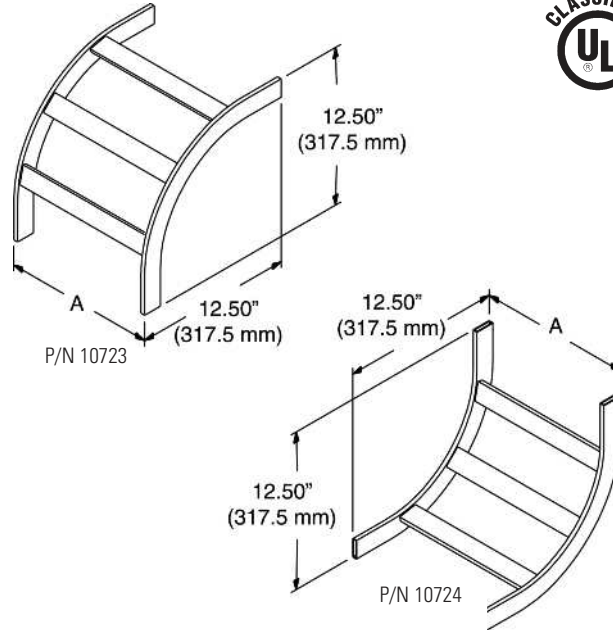

Part Number		
90-Degree Outside Bend	90-Degree Inside Bend	Width (Dim. A) in (mm)
10723-X04	10724-X04	4 (100)
10723-X06	10724-X06	6 (150)
10723-X08	10724-X08	8 (200)
10723-X09	10724-X09	9 (230)
10723-X10	10724-X10	10 (250)
10723-X12	10724-X12	12 (300)
10723-X15	10724-X15	15 (380)
10723-X18	10724-X18	18 (460)
10723-X20	10724-X20	20 (510)
10723-X24	10724-X24	24 (610)
10723-X31	10724-X31	30 (760)
10723-X37	10724-X37	36 (910)

X=Color: 0=Gold, 1=Gray, 2=Computer Beige, 7=Black, E=Glacier White.
 Note: Only gold radius bends are UL Classified.

800-834-4969 in U.S. & Canada • www.chatsworth.com

US & Canada

+1-800-834-4969
 Toronto, Ontario, Canada
 +905-850-7770
chatsworth.com

Latin America

+52-55-5203-7525
 Toll Free within Mexico
 01-800-01-7592
chatsworth.com.co

Europe

+44-1628-524-834
chatsworthproducts.co.uk

Middle East & Africa

Dubai, UAE
 +971-4-2602125
chatsworthproducts.co.uk

Asia Pacific

+86 21 6880-0266
chatsworth.com.cn



CHATSWORTH
 PRODUCTS

techsupport@chatsworth.com