

# Rittal – The System.

Faster – better – everywhere.

Blue e+ chiller  
for cooling media



SK 3320200

SK 3334300

SK 3334400

Assembly and operating instructions

ENCLOSURES

POWER DISTRIBUTION

CLIMATE CONTROL

IT INFRASTRUCTURE

SOFTWARE & SERVICES

FRIEDHELM LOH GROUP



# Contents

EN

## Contents

1	Notes on documentation .....	4	6	Commissioning .....	18
1.1	General .....	4	6.1	Cooling medium water-glycol mixture.....	18
1.2	CE conformity .....	4	6.1.1	General remarks .....	18
1.3	Storing the documents.....	4	6.1.2	Cooling medium requirements .....	18
1.4	Symbols used in these operating instructions	4	6.1.3	Preparation and care .....	19
1.5	Other applicable documents .....	4	6.1.4	Recommended "Cooling medium for chillers" .....	19
2	Safety notes .....	4	6.2	Filling the cooling medium .....	20
2.1	General.....	4	6.3	Bleeding the cooling medium pump .....	20
2.2	Risks in case of failure to observe the safety instructions .....	4	6.4	Commissioning procedure .....	21
2.3	Safety instructions for assembly, inspection and maintenance work .....	4	6.5	Adjusting the bypass valve .....	21
2.4	Unauthorised operation.....	5	7	Operation .....	21
2.5	Health risks due to the refrigerant R134a and the cooling medium .....	5	7.1	General .....	21
2.6	First aid measures.....	5	7.2	Layout of the display .....	22
2.7	Fire-fighting measures.....	5	7.2.1	Start screen .....	22
2.8	Safety measures and equipment.....	5	7.2.2	Changing a parameter value .....	22
2.9	Potential hazards and how to avoid them.....	6	7.2.3	Help function .....	23
3	Device description .....	7	7.3	Info menu.....	23
3.1	General.....	7	7.3.1	Temperature info .....	23
3.2	General functional description .....	8	7.3.2	Device info .....	23
3.3	Control.....	9	7.3.3	Efficiency info .....	24
3.4	Characteristic curves.....	9	7.3.4	Hydraulic info .....	24
3.4.1	Characteristic curves of pump .....	9	7.4	Configuration menu.....	24
3.4.2	Performance diagrams .....	10	7.4.1	Control parameters .....	25
3.5	Safety devices.....	10	7.4.2	Remote .....	28
3.6	Options.....	10	7.4.3	Network .....	28
3.6.1	Inverter pump .....	10	7.4.4	Alarm relays .....	29
3.6.2	Reinforced pump .....	10	7.4.5	Language settings .....	29
3.6.3	Outdoor .....	10	7.4.6	Self-test .....	29
3.6.4	Oil/emulsion .....	10	7.5	System messages.....	30
3.6.5	Free Cooling .....	10	7.5.1	Occurrence of a malfunction .....	30
3.6.6	Water-cooled condenser .....	10	7.5.2	Display in case of errors .....	30
3.6.7	Tank heating .....	10	8	Inspection and maintenance .....	30
3.7	Proper use, foreseeable misuse .....	10	8.1	Maintaining the refrigerant circuit .....	31
3.8	Supply includes.....	11	8.2	Monitoring the cooling medium .....	31
4	Transport .....	11	8.3	Cleaning the condenser .....	32
4.1	Delivery .....	11	8.4	Cleaning the filter mat (accessories).....	32
4.2	Unpacking .....	11	8.5	Draining the cooling medium tank .....	32
4.3	Transport.....	11	9	Troubleshooting .....	33
5	Assembly and connection .....	13	9.1	List of system messages .....	34
5.1	Dimensions .....	13	10	Decommissioning and disposal .....	36
5.2	Installation site requirements .....	13	10.1	Decommissioning.....	36
5.3	Installing the chiller.....	14	10.2	Disposal.....	36
5.4	Making the hydraulic connection.....	14	11	Accessories .....	37
5.5	Connecting the cooling circuit (optional).....	15	11.1	Connection set for air/water heat exchangers .....	37
5.6	Making electrical connection .....	15	11.2	Flow regulator valve.....	37
5.6.1	Installing the power supply .....	16	11.3	Textile filter mats .....	37
5.6.2	Connecting the alarm relay query device .....	16	11.4	Metal filter (aluminium filter).....	38
5.6.3	External activation .....	16	11.5	Cooling medium for chillers (ready-mix) .....	38
5.6.4	Room temperature sensor (accessories) .....	16	11.6	Levelling feet .....	38
5.7	Installing the filter mats (accessories).....	16	11.7	Twin castors.....	38

---

12	Appendix .....	40
12.1	Block diagram.....	40
12.2	Spare parts.....	41
12.3	Technical specifications .....	42
12.4	Device drawings .....	43
12.5	Operation of inverter pump .....	46
12.6	Declaration of Conformity.....	47

## 1 Notes on documentation

### 1.1 General

These instructions are aimed at installers and operators who are familiar with the installation and the operation of the chiller. It is very important to read and follow these assembly and operating instructions prior to commissioning. These are the original operating instructions.

### 1.2 CE conformity

Rittal GmbH & Co. KG confirms the conformity of the chiller with the European Union's Machinery Directive 2006/42/EC and EMC Directive 2004/108/EC. A corresponding declaration of conformity has been issued and enclosed with the unit.



### 1.3 Storing the documents

The assembly and operating instructions as well as all other applicable documents are an integral part of the product. They must be issued to everyone who works with the chiller and must always be available and on hand for operating and maintenance personnel.

### 1.4 Symbols used in these operating instructions

The following symbols are used in this documentation:



#### **Danger!**

**A dangerous situation in which failure to comply with the instructions will result in death or severe injury.**



#### **Warning!**

**A dangerous situation which may cause death or serious injury if the instructions are not followed.**



#### **Caution!**

**A dangerous situation which may lead to (minor) injuries if the instructions are not followed.**



#### **Note:**

Important notices and indication of situations which may result in material damage.

- This symbol indicates an "action point" and shows that you should perform an operation or procedure.

## 1.5 Other applicable documents

Assembly and operating instructions exist as paper documents and/or digital data carriers for the unit types described here and are enclosed with the equipment.

We cannot accept any liability for damage associated with failure to observe these instructions. Where applicable, the instructions for any accessories used also apply.

## 2 Safety notes

### 2.1 General

Please observe the following general safety notes when operating and installing the chiller:

- Assembly, installation and maintenance must only be carried out by qualified personnel.
- Children and persons with limited cognitive/coordination abilities must not operate, maintain or clean the unit or be allowed to use it as a toy.
- Only use original spare parts and accessories authorised by the manufacturer to ensure the protection and safety of the chiller. The usage of other parts will render any liability void.
- Do not make any changes to the chiller that have not been agreed with and approved by the manufacturer.
- It is also imperative that you observe the special safety instructions for the individual activities in the individual chapters.

### 2.2 Risks in case of failure to observe the safety instructions

In case of failure to observe the safety notes, people, the environment and the chiller may be placed at risk. Failure to comply with the safety notes makes all claims for compensation void.

### 2.3 Safety instructions for assembly, inspection and maintenance work

- The installation, commissioning and servicing of the chiller must be carried out in strict compliance with the technical documentation for the chiller and in such a way that no potentially hazardous situations are allowed to occur.
- Cleaning and maintenance work on the chiller must only be performed with the unit shut down. For this purpose, it is vital to ensure that the chiller is disconnected from the power supply and is secured against switching back on. It is imperative that you observe the procedure for shutting down the chiller described in the assembly and operating instructions.
- All safety devices and protective equipment must be reattached or put in a functional condition immediately after the work is complete.
- Modifications or changes to the chiller are not allowed.
- Only appropriately qualified personnel as defined by BGR500 chap. 2.35 / EN 378 are allowed to work on the refrigerant circuit.

- Do not install the chiller without protection outside of covered areas, or in an explosive or aggressive environment.
- Do not install the chiller on an unstable surface or a surface that is not designed for the weight of the chiller.
- Do not bypass any electrical safety devices to make it possible to operate the chiller.

## 2.4 Unauthorised operation

The safety of the chiller supplied is only ensured if it is used properly (see section 3.7 "Proper use, foreseeable misuse"). Under no circumstances should the limit values specified in the technical data be exceeded.

The chiller is not allowed to be used for the direct cooling of liquids that are used for foodstuffs (e.g. drinking water).

Any existing contact hazard protection for moving parts must not be removed from chillers while operational. Hazards due to electrical power, do not remove any switch box cover!



### Explosion hazard!

**The use of the chiller for cooling inflammable or pyrophoric substances is prohibited.**

## 2.5 Health risks due to the refrigerant R134a and the cooling medium

The refrigerant changes status during operation and becomes pressurised. The R134a safety data sheet must be observed.

The cooling medium (additive) is a liquid. We suggest: "Cooling medium for chillers" (see section 6.1 "Cooling medium water-glycol mixture"). The safety data sheet "Cooling medium for chillers" must be observed.

## 2.6 First aid measures

Please refer to safety data sheets R134a and "Cooling medium for chillers".



Note:

Safety data sheets are available for downloading at [www.rittal.com](http://www.rittal.com).

## 2.7 Fire-fighting measures

### Suitable extinguishing agent

All known extinguishing agents can be used.

## 2.8 Safety measures and equipment

- Ensure adequate ventilation.
- Hand protection: Safety gloves.
- Eye protection: Safety goggles.
- Body protection: Wear safety shoes when handling pressurised gas bottles.

## 2 Safety notes

EN

### 2.9 Potential hazards and how to avoid them

The following table provides an overview of other potential sources of danger and how to avoid them.

Location	Hazard	Cause	Precautionary measures
Device interior	Severe personal injury or damage to property	Hazard due to electrical equipment of the chiller	Recurrent testing of electrical equipment (Germany BGV A3)
Device interior	Personal injury or damage to property	Electrical hazard while working on the chiller	The power to the chiller must be disconnected via the main switch.
Device interior	Inhalation of toxic gases/materials	Soldering work inside the chiller may release toxic gases due to the installed cooling circuit.	Maintenance may only be carried out by specialist personnel. Before carrying out soldering work on the cooling circuit or in its immediate vicinity, the refrigerant should be drained from the chiller.
Device interior	Risk for the product	Liquid level after transport not in upright position	Only transport the chiller upright. Should the chiller be tilted during transportation, please wait some minutes before switching on again.
Device interior: Micro-channel condenser	Minor cuts	Contact while cleaning the condenser (see section 8.3 "Cleaning the condenser")	Wear safety gloves.
Device interior: Hot or cold parts	Burns / frostbite	Contact with parts with a high or low surface temperature.	The chiller may only be opened by trained, qualified personnel.
Device interior: Cooling medium circuit	Fungus and algae formation	Use of pure water as a cooling medium or refrigerant.	Use a water-glycol mixture as your cooling medium. Rittal recommends the use of "Cooling medium for chillers" (ready-mix).
Device exterior	Severe personal injury or damage to property	The floor on which the chiller is installed is unstable and unable to support its weight. The chiller tips over or the floor gives way.	The weight of the chiller can be found in section 12.3 "Technical specifications". Additionally, please allow for the weight of the liquid in the tank (the capacity of the tank can likewise be found in section 12.3 "Technical specifications") and make sure that the floor is suitable for installation purposes.
Device exterior	Personal injury or damage to property	Hazards when transporting or assembling the chiller	Secure the chiller against any risk of tilting (eyebolts) when transporting or assembling.
Device exterior	Cuts	Contact with fan wheel	Do not remove the protective cover around the fan wheel.
Device exterior: Area around the chiller	Major burns	Fire caused by short-circuiting or overheating of the electricity supply line to the chiller	Ensure that the cable cross-section and electricity supply line comply with the valid regulations.
Device exterior: Chiller with wheels	Personal injury or damage to property	The chiller starts to move due to unevenness of the floor surface.	If the recooling system is equipped with wheels (option), they must be locked with brakes while operational.

Tab. 1: Hazards and precautionary measures



**Note:**

Specialist personnel are individuals who, by virtue of their training, education, experience and knowledge of the relevant provisions, regulations and measures for accident prevention and relating to the operating conditions, have been authorised by the owner or responsible individual to ensure the safety of the system, carry out all essential tasks, and are therefore in a position to identify and avert all potential threats.

## 3 Device description

### 3.1 General

Chillers are used for the central and economical cooling and supply of a cooling medium (water + glycol, see section 6.1 "Cooling medium water-glycol mixture") in the event of physical separation between the place where cooling is required and the refrigeration. The cooling medium is supplied using a pipe system.

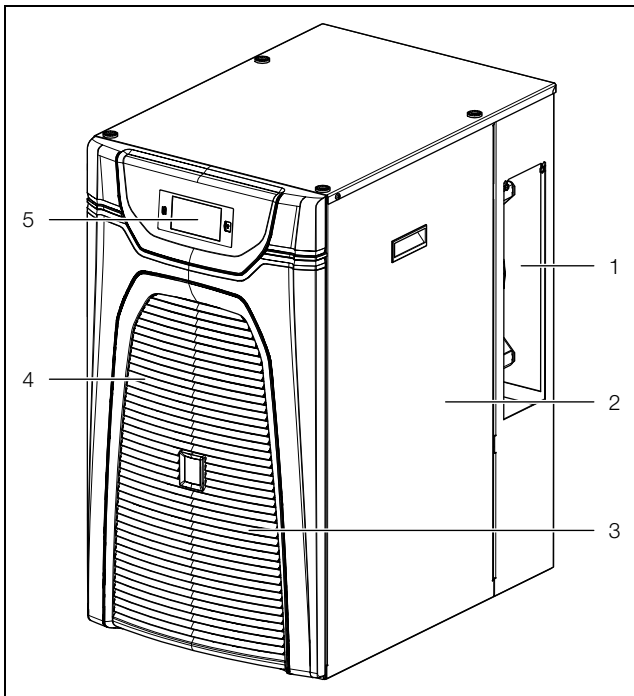

Fig. 1: View from front (3320200 and 3334300)

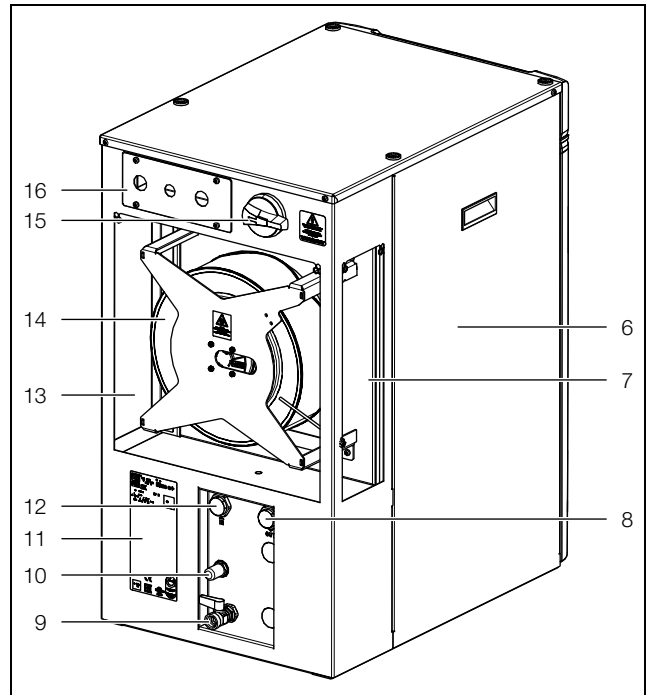

Fig. 2: View from rear (3320200 and 3334300)

**Key fig. 1 and fig. 2**

- 1 Side air outlet, right
- 2 Side cover, right
- 3 Filler nozzle for cooling medium (behind louvred grilles)
- 4 Louvred grille for air inlet
- 5 Display
- 6 Side cover, left
- 7 Side air outlet, left
- 8 Cooling medium connection, inlet
- 9 Tank drain nozzle (stop valve)
- 10 Adjustable overflow valve (bypass)
- 11 Rating plate
- 12 Cooling medium connection, return
- 13 Air outlet, rear
- 14 Radial fan
- 15 Master switch
- 16 Electrical interfaces

# 3 Device description

EN

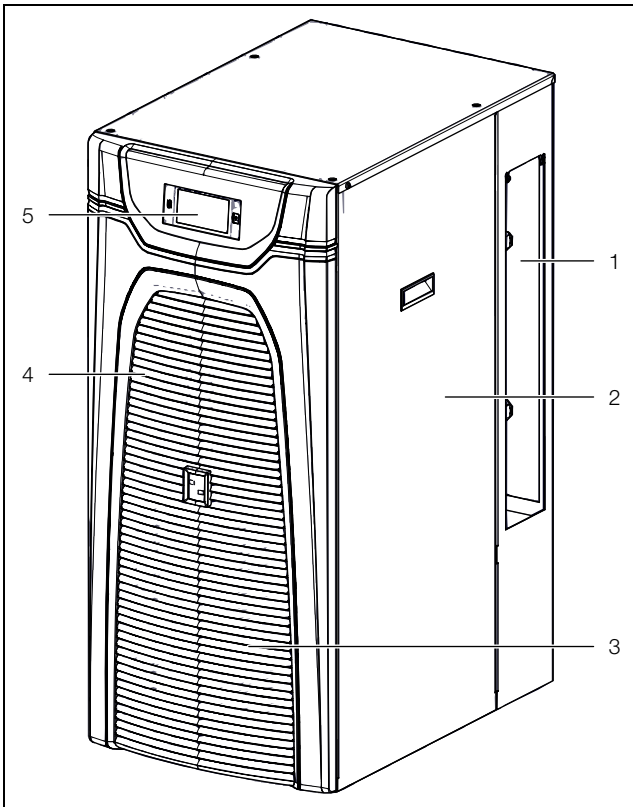

Fig. 3: View from front (3334400)

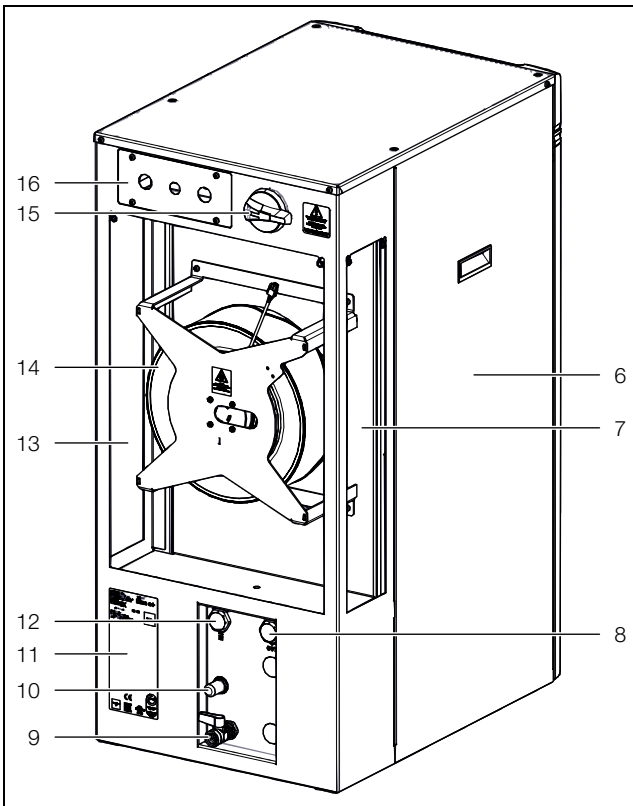

Fig. 4: View from rear (3334400)

## Key fig. 3 and fig. 4

- 1 Side air outlet, right
- 2 Side cover, right
- 3 Filler nozzle for cooling medium (behind louvered grilles)
- 4 Louvred grille for air inlet
- 5 Display
- 6 Side cover, left
- 7 Side air outlet, left
- 8 Cooling medium connection, inlet
- 9 Tank drain nozzle (stop valve)
- 10 Adjustable overflow valve (bypass)
- 11 Rating plate
- 12 Cooling medium connection, return
- 13 Air outlet, rear
- 14 Radial fan
- 15 Master switch
- 16 Electrical interfaces



### Note:

The motor circuit-breaker of the cooling medium pump is accessed by opening the roof plate. See also Q1 in section 12.1 "Block diagram".

The chiller is equipped with an open reservoir for the cooling medium.

## 3.2 General functional description

The chiller comprises four main components (see fig. 5):

- Evaporator coil (item 12),
- refrigerant compressor (item 13),
- condenser (item 1) with fan (item 2),
- control or expansion valve (item 4),

which are connected together by pipes. A pressure switch (item 14) limits the maximum pressure in the refrigerant circuit. The refrigerant R134a (CH<sub>2</sub>FCF<sub>3</sub>) is chlorine-free. Its Ozone Depletion Potential (ODP) is 0. A filter drier (item 3) which is integrated into the hermetically sealed refrigerant circuit provides effective protection against moisture, acid, dirt particles, and foreign bodies. A temperature control with temperature probe (item 6) ensures that the cooling medium is maintained at a preset setpoint temperature.

In the evaporator coil (item 12), the liquid refrigerant is converted to a gaseous state. The heat necessary for this purpose is taken from the cooling medium in the plate heat exchanger, which has the effect of cooling the cooling medium. The refrigerant is compressed in the compressor (item 13). As a result the refrigerant has a higher temperature than the ambient air. The DC inverter technology enables load-specific speed control of the compressor motor, so that only the power actually needed is supplied.

This heat is dissipated to the ambient air over the surface of the condenser (item 1), resulting in the refrigerant liquefying again. A water-cooled condenser may optionally be used (see section 3.6.6 "Water-cooled condenser").



The refrigerant is injected into the evaporator (item 12) via an electronic expansion valve (item 4), causing it to expand and as a consequence is able to absorb the heat from the cooling medium (water or water-glycol mixture). The cooling medium is pumped to the equipment in an additional circuit via the cooling medium tank (item 10) and the cooling medium pump (item 9). The flow sensor (item 11) ensures that the evaporator (item 12) is protected against freezing and running dry if the flow rate is too low. The level switch (item 5) emits a warning if the level in the cooling medium tank is too low. The inlet temperature of the cooling medium (water or water-glycol mixture) is regulated using the temperature sensor (item 6) on the water outlet. Optionally, an inverter pump may also be used, so that the cooling medium pump is also speed-controlled.

A layout drawing of the refrigerant circuit may be found in fig. 5.

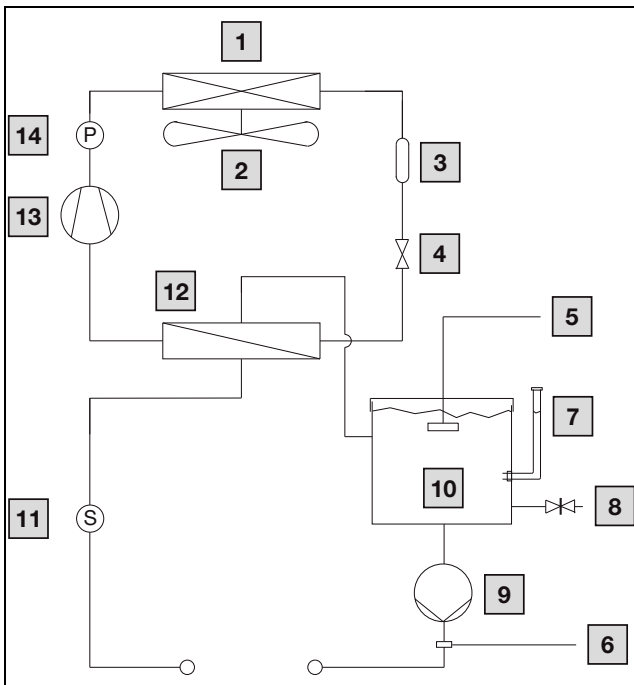

Fig. 5: Schematic diagram of refrigerant circuit

**Key**

- 1 Condenser, air-cooled
- 2 Condenser fan (radial fan)
- 3 Filter dryer
- 4 Expansion valve
- 5 Fill level monitoring
- 6 Temperature sensor
- 7 Fill nozzle
- 8 Tank drain nozzle
- 9 Cooling medium pump
- 10 Cooling medium tank
- 11 Flow sensor
- 12 Evaporator (plate heat exchanger)
- 13 Compressor
- 14 Pressure-operated switch

### 3.3 Control

The chillers are fitted with a controller for setting the functions of the chiller.

Operation using this controller is described in section 7 "Operation".

Within the compressor speed range from 25...100%, the compressor is in continuous control mode. During continuous control mode, the control accuracy of the water inlet temperature is  $\pm 0.5$  K or better. At smaller loads requiring a speed of less than 25%, the compressor switches to cycle mode, and the control accuracy of the water inlet temperature is adjusted to  $\pm 2$  K (refer to the performance curves on the Rittal website).

### 3.4 Characteristic curves

#### 3.4.1 Characteristic curves of pump

Characteristic curves measured under the following conditions:

- Ambient temperature ( $T_a$ ) = 32°C
- Medium temperature ( $T_w$ ) = 18°C
- Cooling medium "water"

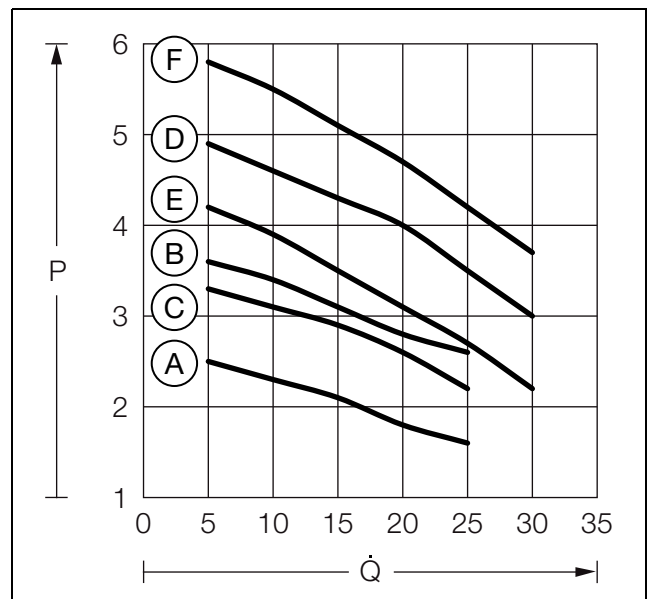

Fig. 6: Characteristic curves

**Key fig. 6**

- A 3320200 standard pump 50 Hz
- B 3320200 standard pump 60 Hz
- C 3320200 reinforced pump 50 Hz (option) or 3334300 and 3334400 standard pump 50 Hz
- D 3320200 reinforced pump 60 Hz (option) or 3334300 and 3334400 standard pump 60 Hz
- E 3334300 and 3334400 reinforced pump 50 Hz (option)
- F 3334300 and 3334400 reinforced pump 60 Hz (option)
- P External static pressure [bar]
- Q Delivery flow [l/min]

The flow speed of the circulating medium is monitored with a flow sensor. The sensor has a preset alarm threshold and a variable warning threshold that can be

## 3 Device description

EN

set by the operator. When the warning threshold is reached, a message is produced, and when the alarm threshold is reached, a fault is generated.

If the flow rate of the circulating medium during operation drops below 4 l/min, the integrated flow sensor will trip.

### 3.4.2 Performance diagrams

The performance diagrams can be found on the Rittal website.

### 3.5 Safety devices

- In the cooling circuit, the chiller has a type-tested pressure monitor (to EN 12263) which switches off the chiller if the maximum admissible pressure is exceeded. Once the pressure drops back below the admissible pressure, the unit will automatically resume operation.
- Temperature monitoring prevents the evaporator coil from icing over. The compressor gradually reduces the output within the range 100...25%. If the risk of icing persists for more than 2 minutes, the compressor will switch off completely. At higher temperatures, the unit automatically returns to control mode.
- The compressor motor and the fan motor are monitored and protected by the inverter to prevent overloading.
- The cooling medium pump has a motor circuit-breaker to prevent overcurrent and short-circuits.
- To ensure smooth-running and reliable operation (for example after reaching the setpoint temperature or after a fault), the compressor automatically switches back on after a delay.
- The chiller has floating contacts on terminals 8 to 10 of the signal connector (X2), via which system messages from the device may be polled, e.g. using a PLC (2 x normally closed or normally open contacts).

### 3.6 Options

#### 3.6.1 Inverter pump

The cooling medium pump can be designed as an inverter pump. In such cases, the pump is speed-controlled depending on the actual cooling medium demand (see section 12.5 "Operation of inverter pump").

#### 3.6.2 Reinforced pump

For applications requiring a higher cooling medium throughput or pressure, the cooling medium pump can be designed in a higher output category.

#### 3.6.3 Outdoor

The "Outdoor" option allows the chiller to be sited outside. To this end, the chiller is coated with a special spray-finish. Outdoor siting means that the air at the system installation site is not additionally subject to waste process heat.

For outdoor siting, a rain canopy should be provided by the customer to protect the chiller from downpours.



Note:

With outdoor siting of the chiller, it is important to ensure that a suitable cooling medium is used (see section 6.2 "Filling the cooling medium"). This is the only scenario in which operation to -20°C is admissible.

#### 3.6.4 Oil/emulsion

Oil or an emulsion may also be used as a cooling medium, instead of the water/glycol mixture used as standard. In such cases, the components in the cooling circuit are adapted accordingly, and the thermal capacity of the cooling medium must be stored in the control system.



Note:

For the purpose of these instructions, we have assumed that a water/glycol mixture is used as the cooling medium.

#### 3.6.5 Free Cooling

The "Free Cooling" option allows you to cool without the refrigerant circuit in so-called hybrid mode. If this type of cooling is preselected in the control system, with outdoor siting of the chiller, the system first attempts to use only the (cold) ambient air to cool the cooling medium. If this is no longer possible because the external temperatures are too high, it automatically activates the conventional cooling circuit to supply the required cooling medium temperature.

#### 3.6.6 Water-cooled condenser

The condenser may be water-cooled. In such cases, a separate cooling circuit must be connected to the condenser.

#### 3.6.7 Tank heating

A tank heater may be installed to pre-heat the cooling medium or for frost protection. A setting is made in the control system to determine when the tank heater is switched on and off.

### 3.7 Proper use, foreseeable misuse

The chiller is only used for cooling water-glycol mixtures. Any other use is deemed improper. One exception to this is operation with the "oil/emulsion" option (see section 3.6.4 "Oil/emulsion").

When using other fluids, please refer to the technical specifications in the appendix, or contact the manufacturer. Under no circumstances should the specified limits in the technical data be exceeded.

The chiller is state of the art and built according to recognised safety regulations. Nevertheless, improper use can pose a threat to the life and limb of the user or third

parties, or result in possible damage to the system and other property.

Consequently, the chiller must only be used properly and in a technically sound condition! Any malfunctions which impair safety should be rectified immediately.

Proper use also includes the observance of the documentation provided and compliance with the inspection and maintenance conditions, and strictly professional use as defined in DIN EN 61000-3-2.

Rittal GmbH & Co. KG is not liable for any damage which may result from failure to comply with the documentation provided. The same applies to failure to comply with the valid documentation for any accessories used.

Inappropriate use may be dangerous. Examples of inappropriate include:

- Use of the chiller for cooling flammable or combustible substances.
- The chiller must never be used for the direct cooling of liquids used in the food industry (e.g. drinking water).
- Use of impermissible tools.
- Improper operation.
- Improper rectification of malfunctions.
- Use of accessories not approved by Rittal GmbH & Co. KG.

### 3.8 Supply includes

Qty.	Description
1	Chiller
1	Shipping bag with
1	– Assembly and operating instructions
1	– Connector
1	– Signal connector
4	– Eyebolt and plastic washer
2	– M25 screw connection
1	– M20 screw connection

Tab. 2: Scope of supply

## 4 Transport

### 4.1 Delivery

The chiller is supplied in a packaging unit in a fully assembled state.

- Check the packaging carefully for signs of damage. Traces of oil on damaged packaging indicate a loss of refrigerant and/or a leak in the chiller. Any packaging damage may be the cause of a subsequent functional failure.

### 4.2 Unpacking

- Only transport the chiller in its original packaging material before commissioning for the first time.
- Remove the packaging materials from the chiller.



Note:

After unpacking, the packaging materials must be disposed of in an environmentally friendly way.

- Check the chiller for any damage that may have occurred during transport.



Note:

Damage and other faults, e.g. incomplete delivery, should be reported immediately, in writing, to the shipping company and to Rittal GmbH & Co. KG.

- Check the supply contents for completeness (see section 3.8 "Supply includes").

### 4.3 Transport

If the chiller is stored or transported at temperatures below freezing, return to room temperature before commissioning. This instruction also applies to the external condenser circuit for a water-cooled condenser (option).

- When transporting the chiller, please make allowance for the weight specified in section 12.3 "Technical specifications".
- Use lifting gear with a suitable load capacity.
- If it is necessary to move the chiller in the factory, you must disconnect all connections on the chiller.
- Before transporting, empty the water circuit and tank (see section 8 "Inspection and maintenance").
- Prevent excessive vibration.
- Only transport the chiller upright.
- Only transport the chiller on the pallet supplied with the chiller or with the eyebolt provided (fig. 7, item 1). Serrated washers for earthing are fitted to the eyebolts in the mounted state. After transportation, the eyebolts are exchanged for the pan-head screws provided. Plastic washers are included in the bag of accessories to protect the paint.
- Protect the chiller from unintentional movement (e.g. when being transported by vehicle).

# 4 Transport

EN

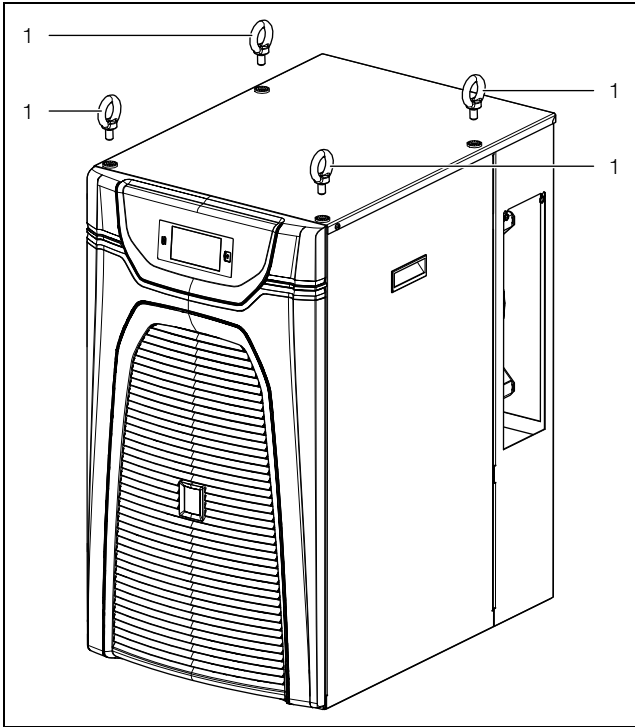

Fig. 7: Eyebolt for transportation (3320200)

## 5 Assembly and connection

### 5.1 Dimensions

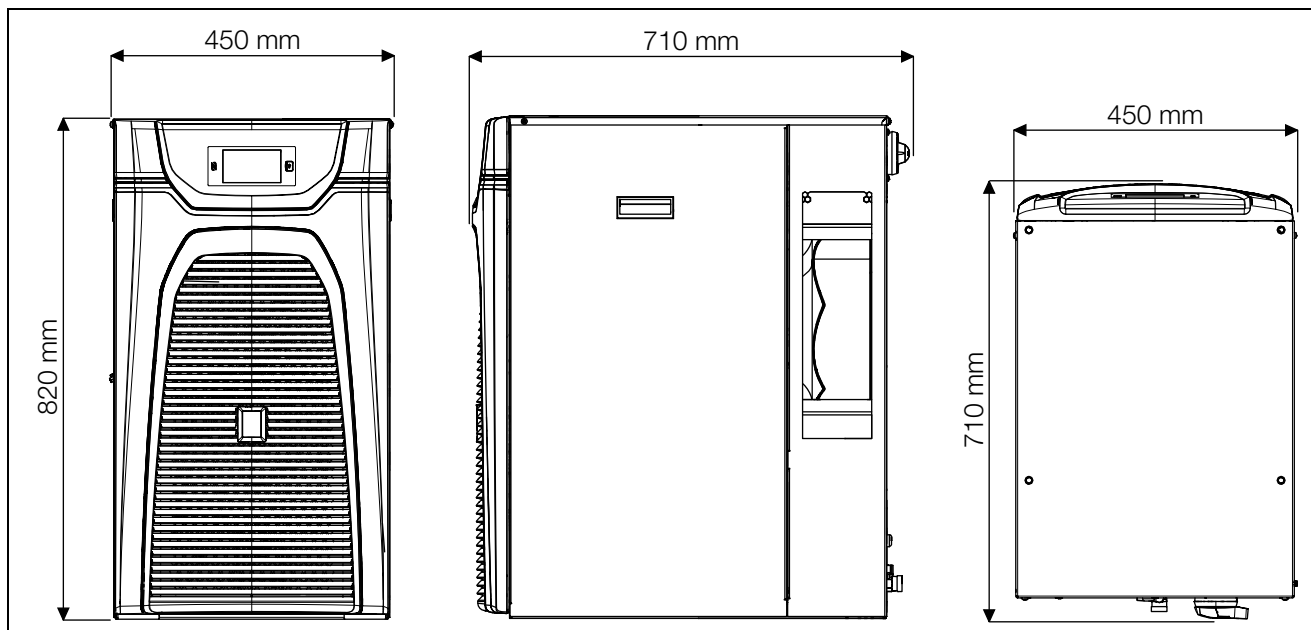

Fig. 8: Dimensions 3320200 and 3334300

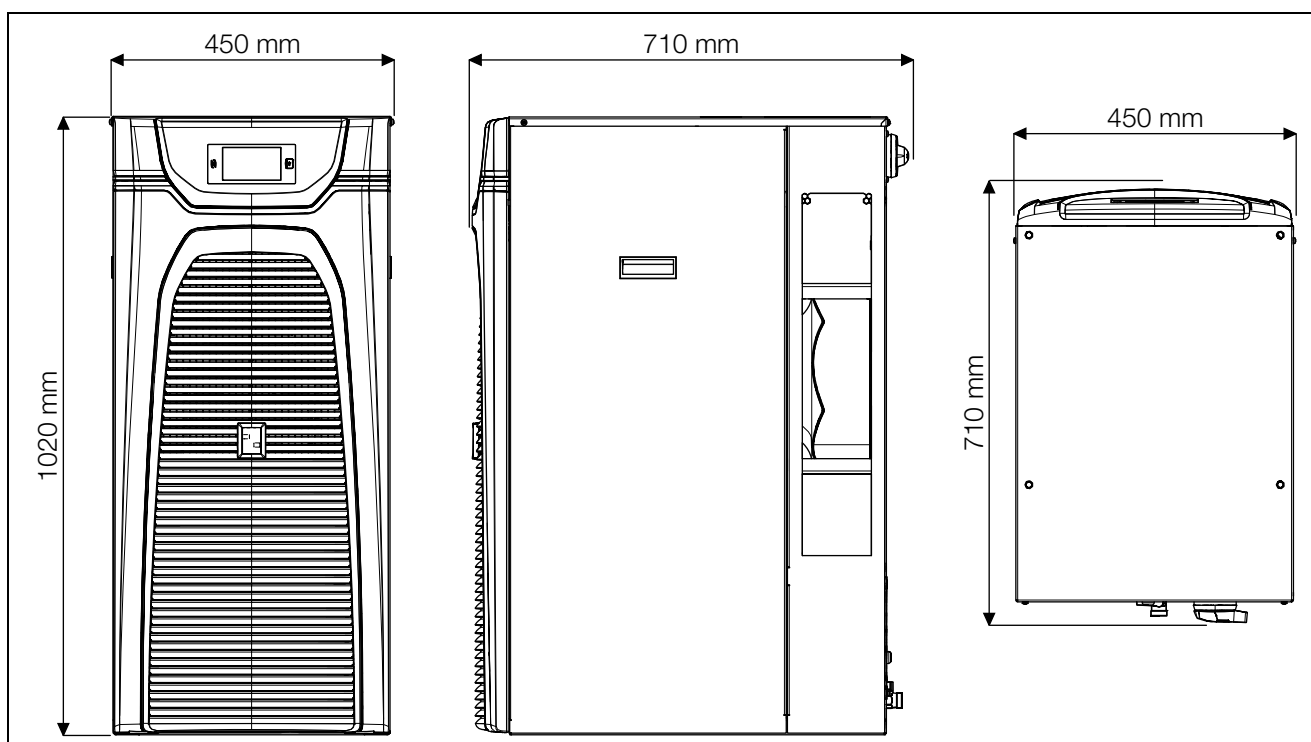

Fig. 9: Dimensions 3334400

### 5.2 Installation site requirements

- The chiller must be adequately protected from external weather conditions.
- If the ambient air contains a high concentration of dust or oily substances, the chiller should be fitted with a metal filter (see section 11.4 "Metal filter (aluminium filter)").
- The supporting surface should be flat and sufficiently robust to hold the weight (see section 12.3 "Technical specifications") during operation.
- If the chiller is sited outdoors, the "Outdoor" option must be used (see section 3.6.3 "Outdoor").
- The ambient temperature must lie within the limit values indicated in the technical specifications (see section 12.3 "Technical specifications").

# 5 Assembly and connection

EN

- In order to prevent performance losses caused by pressure drops in the pipework, the chiller should be sited as close as possible to the equipment.
- At least one of the openings (left or right) must be freely accessible to enable the unhindered expulsion of hot air (see fig. 11). To allow connection of the supply lines and facilitate maintenance and repair work, the minimum distances shown under fig. 10 should be adhered to.
- In order to avoid an "air short-circuit" (mixing of air intake and waste air) and ensure full cooling performance, the minimum distances shown under fig. 10 should likewise be adhered to.

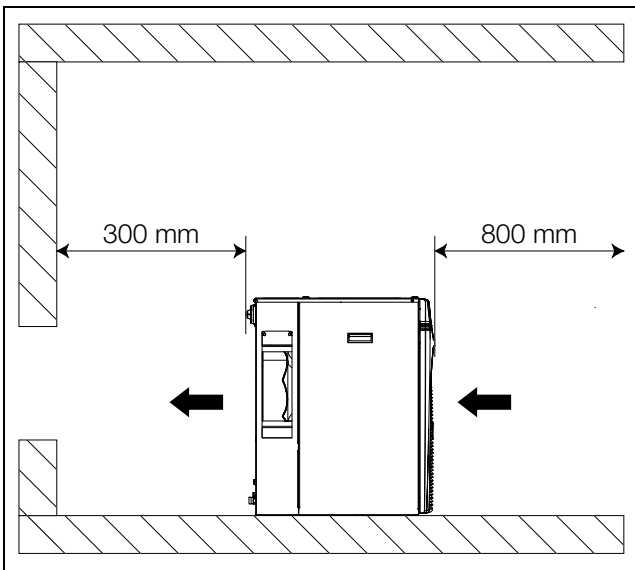

Fig. 10: Minimum distances, front/rear

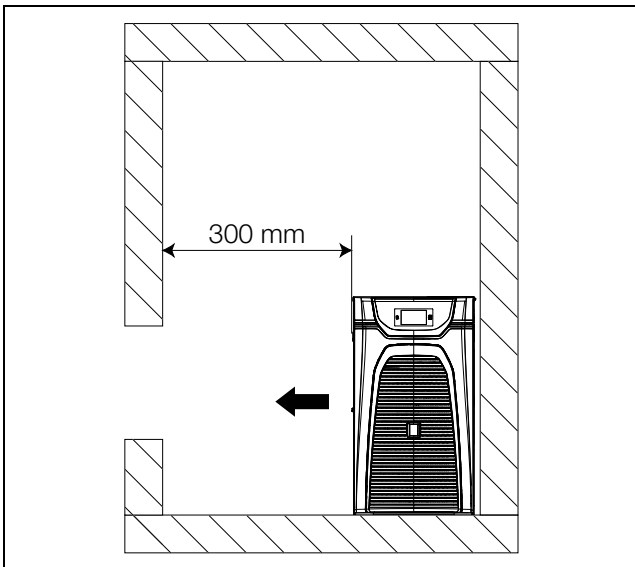

Fig. 11: Minimum distances, sides

- Ensure the room is adequately ventilated by installing the chiller such that the warm exhaust air does not heat the room excessively.
- In case of installation in a "small" room, it is imperative that you provide forced ventilation, as otherwise the heat dissipated will build up.



### Caution!

**The connection of an air intake / waste air duct is inadmissible.**

- To prevent performance losses, do not install the chiller near any form of heating.

### Outdoor siting

Chillers must be installed such that they cannot become damaged by internal traffic and transport operations.

### 5.3 Installing the chiller

- Install the chiller on an even, firm surface. The maximum permissible deviation from the vertical is 2°.
- Avoid the production of noise due to vibration (vibration dampers, sheets of foam rubber).

### 5.4 Making the hydraulic connection



### Caution!

**Risk of damage to the cooling medium pump due to soiling in the cooling medium circuit! Flush the cooling medium circuit prior to connecting the chiller.**

The cooling medium outlet (fig. 2 or fig. 4, item 8) on the chiller must be connected to the cooling medium inlet on the equipment to be cooled. At the same time, the cooling medium inlet (fig. 2 or fig. 4, item 12) on the chiller must be connected to the cooling medium outlet on the equipment to be cooled. Please observe the following:

- To avoid condensation, always connect the equipment using insulated pipelines and/or hoses.
- The nominal width of the piping must correspond at least to the nominal width of the media connections on the chiller.
- The cooling medium infeed to the chiller must be pressureless, because the tank used in the system is open to the atmosphere.
- Never connect the chiller to the drinking water supply.
- The pipework must be approved for the maximum pressure expected (see section 12.3 "Technical specifications").



### Note:

The use of steel pipes or galvanised steel pipes is inadmissible.

Prior to commissioning, it is imperative that the cooling medium pump is filled with cooling medium and bled (see section 6.3 "Bleeding the cooling medium pump").

**Caution!**

**An insufficient flow rate will trigger the safety devices in the chiller. Pay attention to the minimum pressure required and the minimum flow rate required (see section 12.3 "Technical specifications").**

If the cooler on the equipment to be cooled is higher than the chiller, we recommend installing a non-return valve in the feed as well as a solenoid valve in the cooling medium circuit return to prevent the tank from overflowing.

A bypass valve should be connected between the inlet and return to protect the cooling medium pump. This opens automatically, for example, if the equipment cycle is shut off. Section 6.5 "Adjusting the bypass valve" describes how to set the bypass valve.

### 5.5 Connecting the cooling circuit (optional)

If the chiller is equipped with the "water-cooled condenser" option (see section 3.6.6 "Water-cooled condenser"), a cooling water supply must additionally be connected to the condenser.

- Additionally make the cooling water connections to the condenser.

### 5.6 Making electrical connection

- When carrying out the electrical installation, observe all applicable national and regional regulations as well as the regulations from the responsible utility company.
- Electrical installation must only be carried out by a qualified electrician who is responsible for compliance with the existing standards and regulations.
- All cables routed into the wiring compartment have to be insulated for the maximum voltage of the power supply.

**Note:**

The mains supply must be of a shielded design to guarantee the level of EMC protection.

- The cable shielding can contact the earth terminal to the enclosure inside the connection box (fig. 13, item 1).

### Connection data

- The connected voltage and frequency must correspond to the ranges stated on the rating plate. The units support multiple voltages.
- The chiller must be connected to the mains via an all-pole isolating device.
- If a motor circuit-breaker or circuit-breaker is used, it should be selected in accordance with EN 60898-1 (tripping characteristic type D).

- To ensure the proper functioning of internal pressurestats in the event of a malfunction, a slow (time delay) line fuse of no less than 15 A is required.
- Low-noise potential equalisation must be guaranteed with the mains connection. As a general principle, the chiller must be integrated into the building's potential equalisation system.
- The conductor cross-sections of the power cable must be selected according to the rated current (see rating plate).
- The connection must be made with the field rotating clockwise. The direction of rotation of the field can be measured at the connection terminals L1, L2 and L3. Connect with a clockwise rotating field to ensure that the cooling medium pump motor rotates in the correct direction.

### Overvoltage protection and supply line load

- The chiller does not have its own overvoltage protection. Measures must be taken by the operator at the supply end to ensure effective lightning and overvoltage protection.
- The mains voltage must not deviate by more than the tolerance specified in section 12.3 "Technical specifications".
- The chiller and its power electronics are designed in accordance with overvoltage category III. If the combined output of the frequency converters, power converters or transformers in the network where the device is being operated is >70 kVA, the customer must connect a Class II surge voltage protector in the mains supply line upstream of the chiller. The surge voltage protector must be designed to EN 61800 -1. The following values may be assumed as starting-points for the design:

Transformers, power electronics	Assumed discharge energy
70 kVA...100 kVA	40 J
100 kVA...200 kVA	80 J
200 kVA...400 kVA	160 J
400 kVA...800 kVA	320 J

Tab. 3: Design of the surge voltage protector

### Interfaces

If you would like system messages from the chiller to be evaluated via the alarm relay, you should also connect a suitable low-voltage cable to the X2 signal connector (see section 5.6.2 "Connecting the alarm relay query device").

If you require remote activation of the chiller, this can likewise be achieved via the X2 signal connector (see section 5.6.3 "External activation") and appropriate programming (see section 7.4.2 "Remote").



# 5 Assembly and connection

EN

## 5.6.1 Installing the power supply

- Remove the mains connector from the dispatch bag and connect to the mains as shown on the connection diagram (fig. 12).

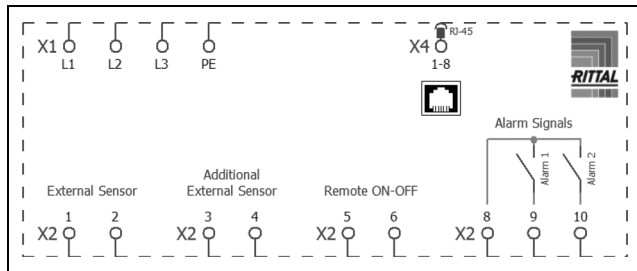

Fig. 12: Circuit diagram

### Strain relief

- Please provide suitable strain relief for the connection cable.
- When connecting the cooling unit in accordance with NFPA 70 (NEC):
- Use the cover for the connection unit and a conduit fitting.
  - Use copper conductors only to connect the supply cable to the mains connector.

## 5.6.2 Connecting the alarm relay query device

System messages from the cooling unit may be output to an external signal source via two floating relay outputs.

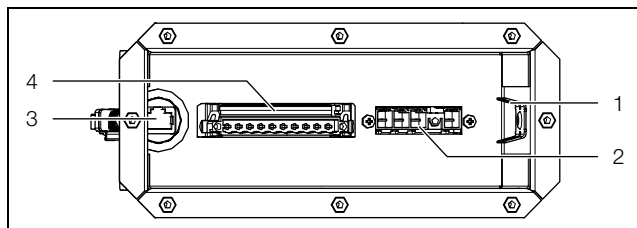

Fig. 13: Connection box

### Key

- 1 Earth tag
- 2 Connector connection (X1)
- 3 IoT interface connection 3124300 (X4)
- 4 Connection for signal connector (X2)



### Note:

The factory setting of the relay outputs in their de-energised state is NO (Normally Open).

- Connect a suitable connection cable to the connection terminals 9 (Alarm K1) and/or 10 (Alarm K2) of the signal connector (X2).
- Configure the alarm relays you wish to use to output error messages (see section 7.4.4 "Alarm relays").

**AC**  
**cos φ = 1**

I max. = 2 A  
U max. = 250 V

Tab. 4: Contact data

## 5.6.3 External activation

The chiller has been prepared for control via an external signal.

- Connect a floating contact to terminals 5 and 6 of the X2 signal connector.
- Configure how you want the external enabling signal to be evaluated (see section 7.4.2 "Remote").

This function is deactivated by default, i.e. the chiller is permanently in operational mode. With the function activated and the contact open, the cooling function and, where applicable, the cooling medium pump are switched off.

## 5.6.4 Room temperature sensor (accessories)

The chiller allows for room-temperature-based control. This requires a room temperature sensor (see section 11.9 "External temperature sensor"), available as an optional accessory.

- Connect the room temperature sensor to terminals 1 and 2 of the X2 signal connector.
- Configure the chiller control mode so that the temperature is regulated by the sensor measurement (see section 7.4.1 "Control parameters").

## 5.7 Installing the filter mats (accessories)

For dry, coarse dust and lint in the ambient air, we recommend installing an additional PU foam filter mat (available as an accessory) in the chiller. Depending on the incidence of dust, you will need to replace the filter mat from time to time (see section 5.7 "Installing the filter mats (accessories)").

For ambient air containing oil, we recommend the use of metal filters (see section 11.4 "Metal filter (aluminium filter)"). These may be cleaned with suitable detergents and reused (see section 8.4 "Cleaning the filter mat (accessories)").

### Types 3320200 and 3334300

- At the front of the chiller, pull the louvred grille (fig. 14, item 3) away from the mounting clips (fig. 14, item 2), and place or lay it down somewhere safe.



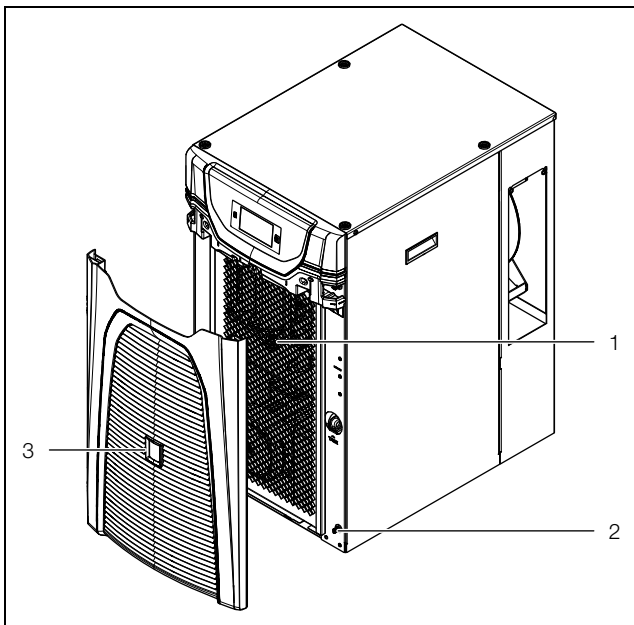

Fig. 14: Pull off the louvred grille 3320200 and 3334300

**Key**

- 1 Filter holder
- 2 Mounting clips (4x)
- 3 Louvred grille

**Textile filter mat**

- Re-insert the filter mat into the frame at the front.
- If necessary, use a tool, such as a screwdriver, to press the filter into the U-section of the frame.

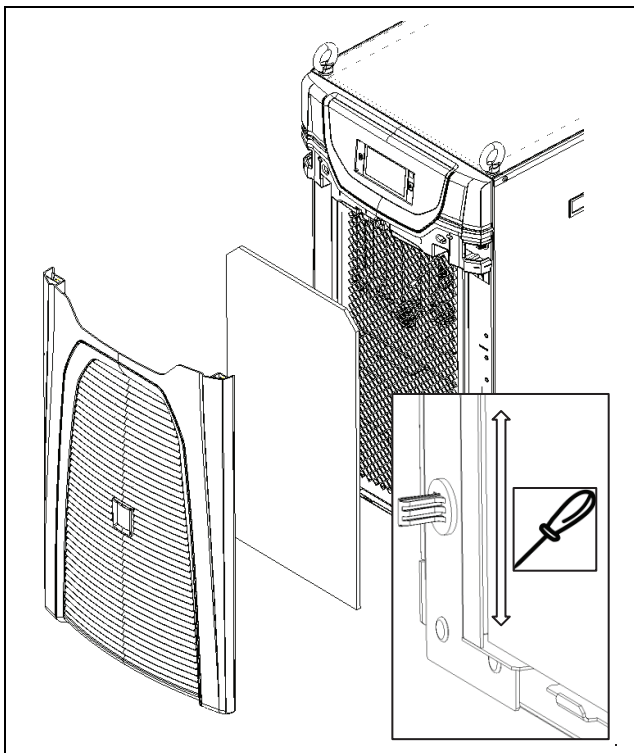

Fig. 15: Insert the textile filter mat 3320200 and 3334300

**Metal filter**

- Position the metal filter on the frame at the bottom.

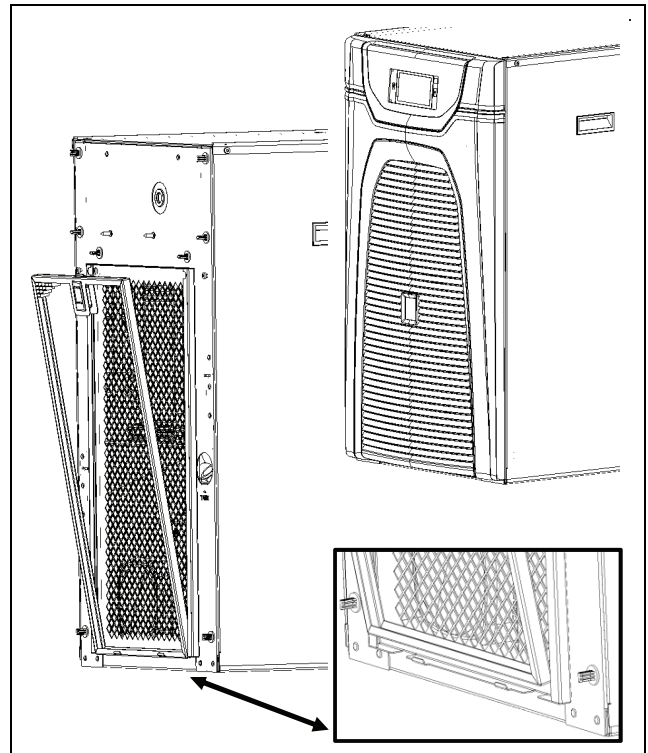

Fig. 16: Insert the metal filter 3320200 and 3334300

- Press in the filter at the top until the lug locks home into the frame.

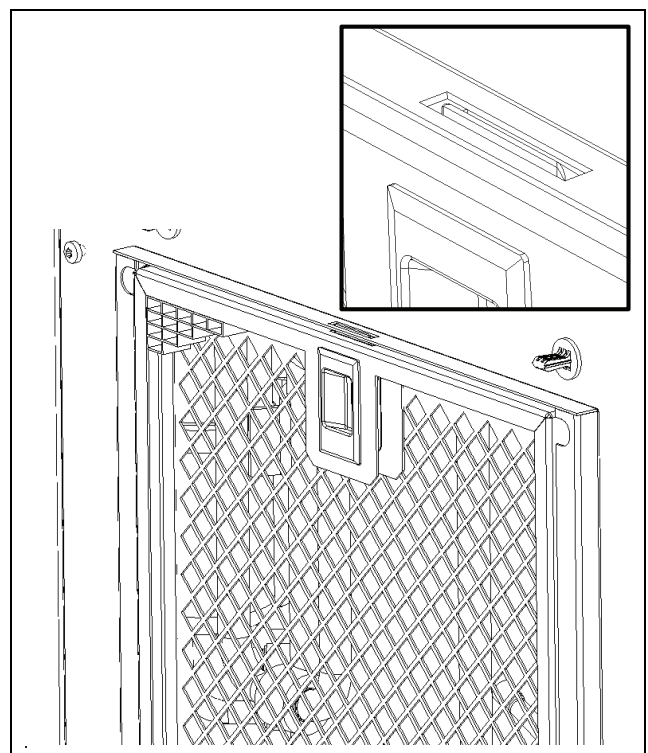

Fig. 17: Press in the metal filter 3320200 and 3334300

**Textile filter mat and metal filter**

- Press the louvred grilles back onto the mounting clips.

**Type 3334400**

- Open the louvred grille below the infill panel by flipping forwards (fig. 18, item 1).

# 6 Commissioning

EN

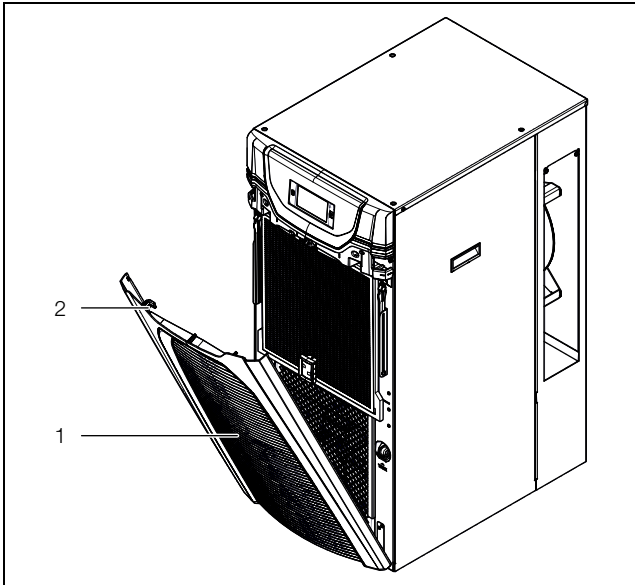

Fig. 18: Flip open the louvred grille 3334400

### Key

- 1 Louvred grille
- 2 Filter holder

- Push the textile filter mat or metal filter into the back of the filter holder on the rear of the louvred grille.
- Push the louvred grille backwards so that it locks home on the chiller.

### Install the pleated filter for the inverter housing

- Remove the left-hand side panel, and place or lay it down somewhere safe.
- If a pleated filter is already installed, loosen the split rivets and remove the pleated filter from the inverter housing.

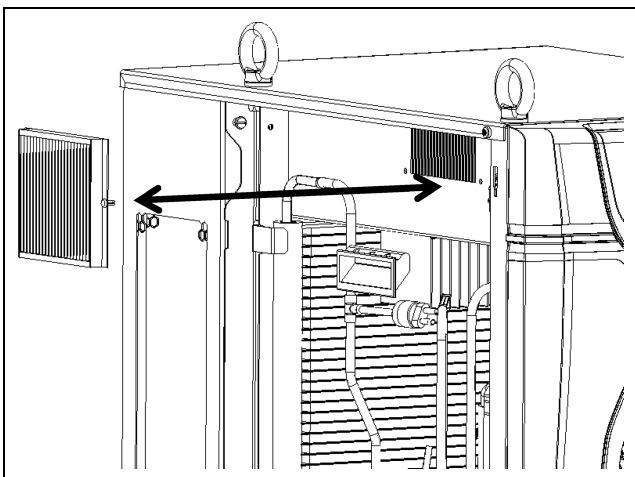

Fig. 19: Insert the pleated filter.

- Insert a new pleated filter and secure with the split rivet.
- Close the side panel again.

## 6 Commissioning

The chiller has a master switch allowing it to be switched off for maintenance work.

In day-to-day operation, it should be switched on and off by the higher-level controller.

### 6.1 Cooling medium water-glycol mixture

As standard, the chiller is not suitable for operation below the specified minimum temperature (see section 12.3 "Technical specifications").

Generally speaking, a water-glycol mixture with a maximum glycol proportion of between 20 and 34% by volume should be used as the cooling medium. We recommend our ready-mixed "Cooling medium for chillers" (see section 6.1.4 "Recommended "Cooling medium for chillers"). Other water-glycol mixtures may be possible in individual cases, but only in consultation with the manufacturer.



#### Caution!

**Other additives may damage the pipes and the seal on the cooling medium pump, and are therefore only admissible by arrangement with Rittal.**



#### Note:

With the chiller sited outdoors ("Outdoor" option), it is important to adjust the glycol proportion accordingly. This can be ensured by using the premixed outdoor medium "Cooling medium for chillers".

### 6.1.1 General remarks

When cooling the water-glycol mixture in an open circuit, always remember that algae, deposits and corrosion can damage the chiller. Residues will always impair the performance of the chiller. Without water treatment it is only seldom possible to achieve satisfactory conditions. By means of regular monitoring of the quality of the cooling medium and cooling medium treatment, you must ensure that deposits and corrosion are avoided, even under extreme conditions.

### 6.1.2 Cooling medium requirements

The cooling medium must not cause any limescale deposits or loose debris. In other words, it should have a low level of hardness, particularly a low level of calcium hardness. In particular, the level of calcium hardness should not be too high when using the equipment for recirculated cooling. On the other hand, the cooling medium should not be so soft that it attacks the materials. When recooling the cooling medium, the salt content should not be allowed to increase excessively due to the evaporation of large quantities of water, since the electrical conductivity will increase as the concentration of dissolved substances rises, and the cooling medium will become more corrosive. For this reason, not only is it al-

ways necessary to add a corresponding quantity of fresh water, but also to remove part of the enriched cooling medium.

Furthermore, the properties of the water used must not deviate from the following list of hydrological data:

Properties	Value
p <sub>H</sub> value	(7) 7.5 – 8.5
Electrical conductivity	200 – 1000 µS/cm
Residue on evaporation	< 500 mg/dm <sup>3</sup>
Sedimentary substances	< 3 mg/dm <sup>3</sup>
Hardness	3 – 8°dH (for German-speaking regions)
Ca + Mg	0.5 – 2 mmol/l (for international region)
Hydrogen carbonate	1 – 5 mmol/dm <sup>3</sup> (60 – 300 mg/dm <sup>3</sup> )
Free CO <sub>2</sub>	< 10 mg/dm <sup>3</sup>
Sulphide	< 0.01 mg/dm <sup>3</sup>
Chloride	< 50 mg/dm <sup>3</sup>
Sulphate	< 250 mg/dm <sup>3</sup>
Nitrate	< 25 mg/dm <sup>3</sup>
Nitrite	< 0.1 mg/m <sup>3</sup>
COD	< 7 mg/dm <sup>3</sup>
NH <sub>4</sub>	< 0.05 mg/dm <sup>3</sup>
Fe	< 0.1 mg/dm <sup>3</sup>
Mn	< 0.1 mg/dm <sup>3</sup>
Cu	< 0.1 mg/dm <sup>3</sup>

Tab. 5: Hydrological data



**Note:**

The cooling medium thickens due to evaporation. You can return the values to within the usual ranges by completely replacing the cooling medium (see section 8.2 "Monitoring the cooling medium").

Only use distilled or de-ionised water in chillers specified for such use (see data sheet in section 12.3 "Technical specifications").

### 6.1.3 Preparation and care

There are specific cooling medium requirements depending on the type of equipment being cooled. A suitable process must then be used to prepare and/or maintain the cooling medium to suit the level of contamination and the size and design of the chiller. The most common types of contamination and most frequently used tech-

niques to eliminate them in industrial cooling are shown in the following table:

Type of impurity	Removal
Mechanical contamination	Filtering of the cooling medium via mesh filter, gravel filter, cartridge filter, or pre-coated filter
Excessive hardness:	Softening of the cooling medium using ion exchange
Moderate content of mechanical contaminants and hardeners	Addition of stabilisers and/or dispersing agents to the water
Moderate levels of chemical contaminants	Addition of passifiers and/or inhibitors to the cooling medium
Biological contaminants, slime bacteria and algae	Addition of biocides to the cooling medium

Tab. 6: Impurities and removal

### 6.1.4 Recommended "Cooling medium for chillers"

Rittal recommends the use of "Cooling medium for chillers" (water-glycol mixture). This is a ready-mixed solution and is therefore suitable for immediate use (without the need for mixing) (tab. 7).

#### Composition

Glycol (20-30% max.) + water (70-80% max.) = ready-mix ("Cooling medium for chillers")

Model No.	Quantity [l]	Application
3301950	10	Outdoor
3301960	10	Indoor
3301955	25	Outdoor
3301965	25	Indoor

Tab. 7: Model numbers – Cooling medium for chillers



**Note:**

When glycol is used, the cooling performance is reduced, depending on the glycol concentration (tab. 8).

# 6 Commissioning

EN

Cooling medium for chillers	Temp. [°C]	Loss of cooling performance compared with pure water [%]
Standard (20% glycol) Antifreeze: -10°C	10	-6
	15	-6
	18	-6
Outdoor (30% glycol) Antifreeze: -20°C	10	-13
	15	-13
	18	-13

Tab. 8: Performance loss

To prevent problems in the cooling medium circuit (including water-cooled chillers), it is imperative that the VGB Cooling Water Guidelines (VGB-R 455 P) are observed.

The correct glycol concentration proportions may be read and determined using a refractometer.

## 6.2 Filling the cooling medium

The composition of the cooling medium is described in section 6.1 "Cooling medium water-glycol mixture".

For commissioning, proceed as follows:

- Ensure that any shut-off valves installed in the cooling medium circuit are open.

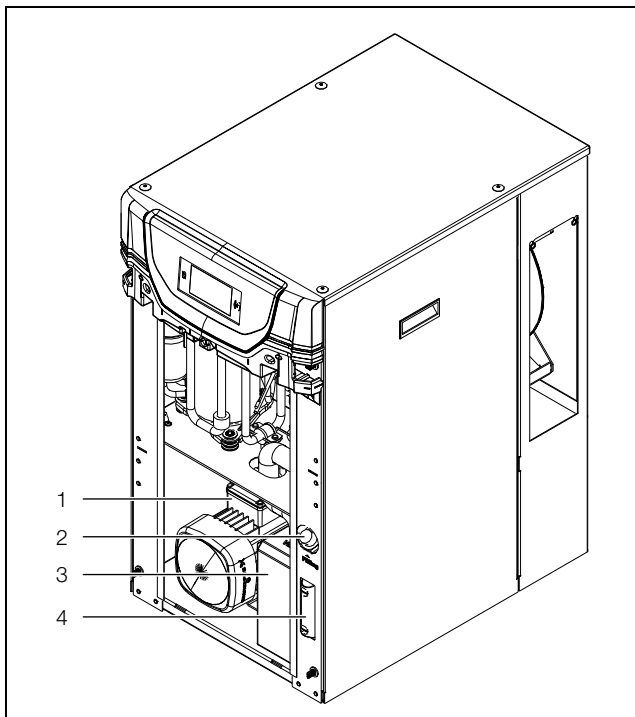

Fig. 20: Filling the cooling medium

### Key

- 1 Cooling medium pump
- 2 Fill nozzle for cooling medium
- 3 Supply tank
- 4 Inspection glass

- At the front of the chiller, pull the louvred grille away from the mounting clips, and place or lay it down somewhere safe.
  - Fill the chiller tank with cooling medium via the fill nozzle (fig. 20, item 2).
  - Check the fill level on the inspection glass (fig. 20, item 4).  
If the "Low fill level" warning appears, top up with approximately 7 litres of cooling medium.
- If the tank is over-filled, or if a leak occurs, the cooling medium will run off via a hole in the centre of the gland plate.



### Note:

Glycol poses a threat to groundwater. The plant operator is obliged to observe the relevant requirements on groundwater protection in his country.

## 6.3 Bleeding the cooling medium pump

- Bleed the pipes and top-up the cooling medium (see section 6.2 "Filling the cooling medium").
- Bleed the cooling medium pump (with the system at a standstill) by loosening the vent screw (fig. 21, item 1). As soon as cooling medium escapes from the vent screw, bleeding of the pump is complete.

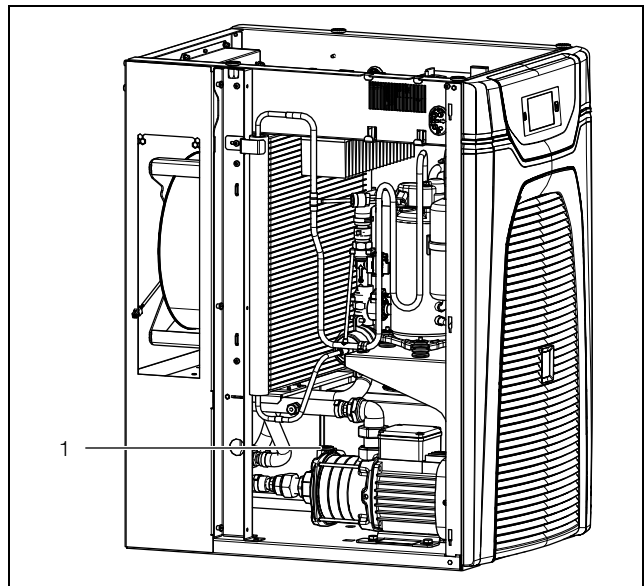

Fig. 21: Bleeding the cooling medium pump

### Key

- 1 Vent screw

- Re-tighten the vent screw.



### Note:

With a water-cooled condenser (option), you must activate the external condenser circuit for the condenser.

- Check the connection lines and pipe connections for leaks during commissioning.

## 6.4 Commissioning procedure

- Before switching on the motor for the first time, or if the position of the display showing the direction of rotation has been altered, check whether the display is working correctly, e.g. by moving the display panel with your finger.
- Switch on the power supply to the chiller via the superordinate controller.
- Switch the master switch into the "I" position.  
The Rittal logo will initially appear on the display, followed a short time later by the start screen.
- Check the direction of rotation of the motor in the cooling medium pump.

The cover of the motor fan is equipped with a display showing the direction of rotation (fig. 22). The motor cooling air is used for the rotation direction display. The correct direction of rotation is also indicated by arrows on the motor fan cover.

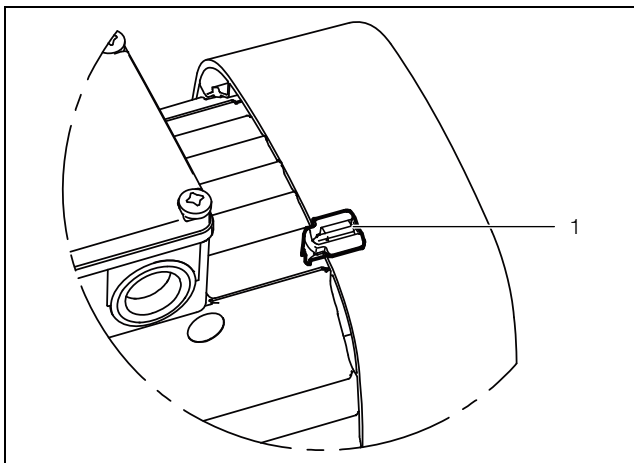

Fig. 22: Checking the direction of rotation

### Key

- 1 Rotation direction display

To determine whether the motor's direction of rotation is correct, compare the display with the information in the following list.

- Display panel "black": Direction of rotation correct
- Display panel "white/reflective": Direction of rotation incorrect
- If the direction of rotation is incorrect, you will need to change over the connections for phases L1 and L2 on the chiller's power supply connector.



### Note:

If the compressor does not start up, the temperature of the coolant added is lower than the setpoint temperature.

- If necessary, lower the setpoint temperature momentarily (see section 7.2.2 "Changing a parameter value").

The cooling air is drawn in from the front and expelled to the rear.

If required, the condenser fan is activated by the temperature controller.

## 6.5 Adjusting the bypass valve

A bypass valve should be connected between the inlet and return to protect the cooling medium pump (fig. 2 or fig. 4, item 10). This opens automatically, for example, if the equipment cycle is shut off. The bypass valve must be adjusted to suit the requirements of the customer's application.

- Open the cover cap of the bypass valve by rotating in a counter-clockwise direction.
- Open the bypass valve by rotating in a counter-clockwise direction.
- Vent the cooling medium pump (see section 6.3 "Bleeding the cooling medium pump") and switch it on.
- Shut off the water flow to the customer application completely using a customer-supplied shut-off valve in the pipeline or in the end application.  
On the chiller display, the current volumetric flow passing through the bypass is shown to the right of the temperature reading (fig. 23, item 3).
- Slowly close the bypass valve by rotating in a clockwise direction until the required flow rate is shown on the display.  
The factory setting is 5...6 l/min at 50 Hz. If a lower value is set, the flow sensor will actuate an alarm message and the pump will stop.
- If the pump stops due to an insufficient flow rate, open the bypass valve by approximately another ¼ turn (approximately).
- Close the cover cap of the bypass valve and open the customer-supplied shut-off valve.

## 7 Operation

### 7.1 General

The chiller is switched on and off by the higher-level control. It operates automatically, i.e. the cooling medium is pumped continuously and heat extracted from it during this process.

When switching on the unit, or following a malfunction, the compressor has an ON delay of 3 minutes, and starts with a reduced compressor output of 33% for 3 minutes. The compressor then enters control mode. If there is a sudden cooling load demand, therefore, cooling medium temperatures may be increased during the startup process.

The chiller is equipped with a touch function display for making basic settings and displaying error messages. This is an industrial-grade touch display which is pressure-sensitive and may therefore be operated with gloves.

As well as operating directly on the chiller itself, there is also a smartphone app available. This offers almost the same functions as the actual display, and additionally



# 7 Operation

EN

provides extended explanations of error messages, as well as the option of contacting the Rittal Service team directly.



Note:

- Use the RiDiag software or an online tool, available on the Rittal website, to check whether the latest firmware version has been installed.

## 7.2 Layout of the display

The display is divided into a top section on a dark background, and a bottom section with the menu bar. This layout is always identical, but the content of the two sections will vary according to the menu selected.

### 7.2.1 Start screen

The start screen is always displayed while the cooling unit is in normal operation, provided there are no error messages.



Fig. 23: Layout of the start screen

#### Key

Item	Description	Possible icons
1	Current medium temperature (3-digit)	Numbers from 0-9
2	EER value: Range 0...10	EER
3	Water flow: Range 0...40 l/min	L/min
4	Display temperature unit	°C °F
5	USB connection (if connected)	USB
6	Self-test (if initiated)	Self-test icon
7	NFC connection (max. 120 seconds after connecting)	NFC

Tab. 9: List of all icons with descriptions

Item	Description	Possible icons
8	Tank heater active (option)	Tank heater icon
9	Type of cooling: Active, free cooling (option), standby	Cooling active, free cooling, standby icons
10	Controlled by an internal or external sensor	Sensor icons
11	External sensor (accessory)	External sensor icon
12	Info menu	Info icon
13	System messages (where applicable)	Warning icon
14	Service icon (if required)	Service icon
15	Configuration	Configuration icon

Tab. 9: List of all icons with descriptions

### Type of cooling

The current form of cooling is indicated by one of the following four icons.

Symbol	Parameter
	Cooling active.
	Cooling with the compressor switched off ("free cooling" option) or hybrid mode.
	No cooling (standby).

Tab. 10: Possible icons for the current type of cooling

### 7.2.2 Changing a parameter value

If a parameter value is changed, the display including the menu bar will also change.

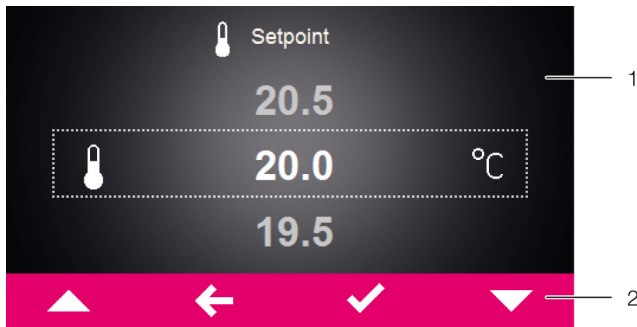

Fig. 24: Screen for changing a parameter value

**Key**

- 1 Main screen
- 2 Control bar

The currently selected parameter value is displayed in the centre of the main screen. To change this value, you always proceed in the same way, as described below with the example of adjusting the set temperature:

- On the start screen, click on the "Configuration" button.
- Enter the PIN to gain access to the lower-level screen pages of the "Configuration" zone. "22" is the default PIN.
- Click on the "Temperature" symbol.
- Click on the "Control mode" symbol.
- Select your preferred control mode from the display.
- Change the setting to the required temperature using the "Up" and "Down" arrows.
- Alternatively, you can also select the one of the displayed higher or lower values directly.
- Finally, confirm the set value with "OK".
- Exit this screen page with the "Back" button.

**7.2.3 Help function**

A help function is offered on selected screens. On these pages, an "info symbol" is visible in the top right-hand corner.

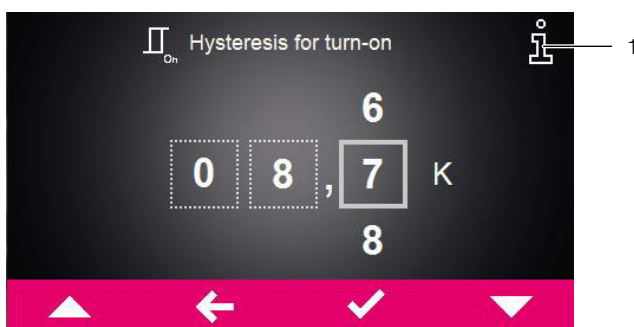

Fig. 25: Screen with help function

**Key**

- 1 Info symbol

- Click on the info symbol at the top right of the page. An information screen showing further information about the relevant parameters will be displayed.

- Exit the information screen by clicking on the "Back" button.

**7.3 Info menu**

- Click on the "Info" symbol to display a list of lower-level screen pages.

Symbol	Parameter
	Temperature info
	Device info
	Efficiency info
	Hydraulic info

Tab. 11: "Info" zone

**7.3.1 Temperature info**

- Click on the "Temperature info" symbol. A list of different temperature values will be displayed.
- Page through the list using the "Up" and "Down" arrows.

Symbol	Parameter
	Av. medium 24h Average medium temperature over the last 24 hours of operation.
	Av. ambient 24h Average ambient temperature (external temperature) over the last 24 hours of operation.
	Current setpoint Current temperature setpoint, depending on the chosen control mode.
	Thresh. Overtemp. Temperature limit which will trigger an alarm message if exceeded.











Tab. 12: "Temperature info" zone

**7.3.2 Device info**

- Click on the "Device info" symbol. A list of general information about the device will be displayed.
- Page through the list using the "Up" and "Down" arrows.

# 7 Operation

EN

Symbol	Parameter
	Article number
	Serial number
	Manufacture date YYYY-MM-DD
	Hardware release x.xx.xx
	Firmware release x.xx.xx
	Software release x.xx.xx
	Last update YYYY-MM-DD
	L. maintenance YYYY-MM-DD
	User device name Name assigned to the cooling unit by the customer. This title can be assigned using the RiDiag software or the Blue e+ app to distinguish between individual units.
	Act. control mode

Tab. 13: "Device info" zone

### 7.3.3 Efficiency info

- Click on the "Efficiency info" symbol.
- Click on the "Efficiency info" symbol.

The average energy efficiency ratio (EER) for the last 24 hours of operation will be displayed. The energy efficiency ratio is the ratio of the cooling output generated to the electrical power used.

 Note:  
The power consumption of the cooling medium pump is not included in the calculation of the EER value (see section 12.3 "Technical specifications").

Symbol	Parameter
	Efficiency info Average energy efficiency ratio (EER) of the last 24 hours of operation.

Tab. 14: "Efficiency info" zone

### 7.3.4 Hydraulic info

- Click on the "Hydraulic info" symbol.  
A list of information about the cooling circuit will be displayed.
- Page through the list using the "Up" and "Down" arrows.

Symbol	Parameter
	Water flow Current flow rate of the cooling medium in l/min.

Tab. 15: "Hydraulic info" zone





### 7.4 Configuration menu

- Click on the "Configuration" symbol.  
A screen page will appear asking you to enter the PIN in order to access the lower-level screen pages.

 Note:  
"22" is preset in the factory as the default PIN.



- For the first digit, page through the digits "0" to "9" using the "Up" and "Down" arrows until the required digit appears in the box.
- Confirm your selection with "OK".
- For the second digit, once again page through the digits "0" to "9" using the "Up" and "Down" arrows until the required digit appears in the box.
- Confirm your selection with "OK".

A list of lower-level screen pages will be displayed.

Symbol	Parameter
	Control param. Settings for set temperature and control mode
	Remote Settings for evaluating the external enabling signal
	Network Display of network information from the IoT interface (3124300)
	Alarm relay Settings for the alarm relays.

Tab. 16: "Configuration" zone







Symbol	Parameter
	Filter mats
	Display language Choice of language for display texts.
	Self-test Perform a self-test.

Tab. 16: "Configuration" zone

### 7.4.1 Control parameters



- Click on the "Control parameters" symbol to display a list of lower-level screen pages.

Symbol	Parameter
	Temperature Settings for set temperature and control mode
	Water flow Setting of alarm limits and start-up attempts.
	Heating (optional) If the "tank heater" option is installed, the relevant settings may be made here.
	Cooling medium

Tab. 17: "Control parameters" zone

### Temperature

- Click on the "Temperature" symbol to display a list of lower-level screen pages.

Symbol	Parameter
	Change unit Set the unit "°C" or "°F"
	Control mode
	Alarm threshold Temperature limit which will trigger an alarm message if exceeded.

Tab. 18: "Temperature" zone

### Temperature > Unit

All temperature values for the unit may be displayed either in degrees Celsius "°C" or degrees Fahrenheit "°F".

- Click on the "Change unit" symbol.
- Change the required unit ("°C" or "°F") using the "Up" or "Down" arrows.
- Confirm your entry with "OK".

### Temperature > Control mode

The chiller can control cooling output according to one of the following two temperature values:

- Cooling medium temperature (fixed value):** Temperature of the cooling medium.
- External temperature sensor:** If the "External temperature sensor" is installed as an accessory, temperature control of the cooling medium can also be based on the temperature in the room where the chiller is located.





Note:

The external temperature sensor is available as accessory from Rittal (see section 11 "Accessories").

- Click on the "Control mode" symbol.

The setpoint for the currently set control mode is displayed.

- Choose your preferred control mode by selecting it from the display:

Symbol	Parameter
	Medium temp.
	External sensor (accessory)

Tab. 19: "Control mode" zone

The corresponding symbol for the chosen control mode is likewise displayed on the overview page.

### Temperature > Control mode > Medium temperature

- Click on the "Medium temperature" symbol.  
The currently set medium temperature is displayed.
- Change the setpoint using the "Up" and "Down" arrows or select the required medium temperature directly.
- Confirm your selection with "OK".



### Temperature > Control mode > External sensor

Please observe the following when selecting the sensor position:

- Where possible, the temperature sensor should not be placed in direct sunlight or in an air current.
- Click on the "External sensor" symbol.  
The prescribed temperature values for controlling the cooling medium temperature are displayed with the aid of the external temperature sensor.
- Choose the required parameter by selecting it from the display:

# 7 Operation

EN

Symbol	Parameter	Setpoint	Factory setting
	Diff. to ext. temp.	-10 K ... 10 K	5 K
	Min. temperature	5°C (41°F) ... current maximum temperature	10°C (50°F)
	Max. temperature	Current minimum temperature ... 35°C (95°F)	28°C (82°F)

Tab. 20: "External temperature sensor" zone



- Change the setpoint using the "Up" and "Down" arrows or select the required temperature directly.
- Confirm your entry with "OK".

With the factory settings, the cooling medium temperature is controlled depending on the value measured by the external temperature sensor, within the following limits:

1. The temperature of the cooling medium is 5 K above the measured temperature value.
2. However, if the measured temperature value drops below 5°C (41°F), the temperature of the cooling medium will remain at 10°C (50°F).
3. However, if the measured temperature value rises above 23°C (73°F), the temperature of the cooling medium will remain at 28°C (82°F).

## Temperature > Alarm threshold

This threshold value is used for an alarm message (over-temperature or undertemperature). The set value must therefore be above or below the actual setpoint to which the cooling unit has been set.

Symbol	Parameter	Alarm threshold	Factory setting
	Over-temperature	+2 K (+3.6°F) ... +15 K (+27°F)	5 K (9°F)
	Subnormal temperature	-2 K (-3.6°F) ... -15 K (-27°F)	Off

Tab. 21: "Alarm limit" zone

- Click on the "Alarm threshold" symbol.

- Choose your preferred type of alarm threshold (over-temperature or undertemperature) by selecting it from the display.
- Change the setpoint using the "Up" and "Down" arrows or select the required temperature directly.
- Confirm your entry with "OK".





Note:

At a water temperature of +2°C, the pump is automatically switched on, and switched off again at +5°C. This frost protection function is always active, regardless of whether or not it has been enabled externally.

## Water flow

- Click on the "Water flow" symbol to display a list of lower-level screen pages.

Symbol	Parameter
	Alarm threshold Lower flow rate threshold, below which a message is emitted.
	Reset flow sensor

Tab. 22: "Water flow" zone

### Water flow > Alarm threshold

This threshold value is used for a message (insufficient flow rate).

**Standard value:** 5 l/min for all output categories.

- Click on the "Alarm threshold" symbol.
- Change the setpoint using the "Up" and "Down" buttons or select the required flow rate (5...15 l/min) directly.
- Confirm your entry with "OK".

### Water flow > Alarm threshold



Below a fixed limit of 4 l/min, the cooling function and the pump are switched off. An alarm is set.

- Reset the error as described in the following section.

### Water flow > Reset flow sensor

If the flow rate is too low ( $\leq 4$  l/min), a corresponding alarm message will appear on the display. In "Manual reset" mode, this message must be manually reset before the pump will restart. In "Automatic reset" mode, a pre-set number of automatic restarts will occur.

- Click on the "Reset flow sensor" symbol.
- Choose the required mode by selecting it from the display.

Symbol	Parameter
	Manual reset
	Automatic reset

Tab. 23: "Reset flow sensor" zone

If "Automatic reset" mode is activated, you will also need to set the number of possible restarts.

- For "Automatic reset" mode, indicate how often the error message should be automatically reset (between once and five times).

"2 restarts" is preselected here as the default.

### Heating (optional)

If the tank heater (optional) is installed for frost protection or to preheat the cooling medium, this can be activated or deactivated here.



- Click on the "Heating" symbol.
- Activate the heater by selecting "On", or deactivate the heater by selecting "Off" (default setting).

### Heating > Heating control

If you have activated the heater, the screen page "heating control" will appear.

- Select the desired parameter.

A screen page similar to the one requesting the PIN for access to the lower-level screen pages of the configuration menu will appear.

Symbol	Parameter	Range	Factory setting
	Hyst. turn-on	1.0 K ... 10.0 K	3.0 K
	Hyst. turn-off	0.5 K...3.0 K	2.0 K

Tab. 24: "Hysteresis values" zone

- One by one, enter the three digits for the hysteresis value and confirm each one with "OK". Please remember that the value for the switch-on hysteresis of the heater must always be higher than the value for the switch-off hysteresis.



#### Note:

When the heater is activated, at a water temperature of +2°C, the pump and heater are automatically switched on, and switched off again at +5°C. This frost protection function is always active, regardless of whether or not it has been enabled externally.

The heater therefore cuts in and out at the following temperatures:

- Switching on: Setpoint temperature of cooling medium - switch-on hysteresis
- Switching off: Activation temperature of heater + switch-off hysteresis

Example:



- Setpoint temperature: 38°C
- Switch-on hysteresis: 3.0 K
- Switch-off hysteresis: 2.0 K

In this case, the heater is switched on and off at the following temperatures:

- Switch-on temperature: 38°C-3.0 K = 35°C
- Switch-off temperature: 35°C+2.0 K = 37°C

### Cooling medium

- Click on the "Cooling medium" symbol to display a list of lower-level screen pages.

Symbol	Parameter
	Water/demi water (option)
	Water-glycol mix
	Oil/emulsion (option)

Tab. 25: "Cooling medium" zone

### Cooling medium > Water-glycol mix

Here, you specify the glycol proportion of the cooling medium if you are using a water/glycol mixture.

- Click on the "Water-glycol mix" symbol.
- Change the glycol proportion using the "Up" and "Down" buttons or select the required value directly. A glycol proportion of between 20% (indoor) and 34% (outdoor) may be selected. This setting will affect the EER calculation. 20% is pre-set as the default.
- Confirm your entry with "OK".

### Cooling medium > Oil/emulsion

If you use the "Cooling medium oil/emulsion" option, you will need to specify the specific thermal capacity of the cooling medium here.

- Click on the "Oil/emulsion" symbol. A screen page similar to the one requesting the PIN for access to the lower-level screen pages of the configuration menu will appear.
- Enter the two digits for the thermal capacity, confirming each one with "OK". The thermal capacity can be set between 1.0 ... 4.9. The default setting is 2.8.

# 7 Operation

## 7.4.2 Remote



- Click on the "Remote" symbol.
- Select how you want the external enabling signal to be evaluated.

Symbol	Parameter
Off	The chiller is permanently in operational readiness, i.e. the external enabling signal is not used (default setting).
Standby	The cooling function and the cooling medium pump are deactivated.
Cooling off	The cooling function is deactivated, the cooling medium pump remains on so that the cooling medium continues to circulate.
Relay function 1	The chiller switches to standby mode in the absence of a signal. If the chiller is in standby mode, alarm relay 1 (contacts 8 and 9 on signal connector X2) will open.
Relay function 2	The chiller switches to standby mode in the absence of a signal. If the chiller is in standby mode, alarm relay 2 (contacts 8 and 10 on signal connector X2) will open.
Relay function 3	The chiller switches to standby mode in the absence of a signal. If the chiller is in standby mode, alarm relays 1 and 2 (contacts 8, 9 and 10 on signal connector X2) will open.

Tab. 26: "External enabling signal" zone

## 7.4.3 Network

- Click on the "Network" symbol to display a list of lower-level screen pages.



Symbol	Parameter
	Network on/off
	Network info

Tab. 27: "Network" zone

### Network on/off

Here, you can activate / deactivate data communication to the IoT interface. Data communication is activated by default.

- Click on the "Network on/off" symbol.
- Select your preferred setting by selecting it from the display.
- Confirm your entry with "OK".



Symbol	Parameter
	Network off
	Network on

Tab. 28: Data communication settings

### Network info

Get IP information about how the IoT interface is incorporated into the network.

- Click on the "Network info" symbol to display a list of lower-level screen pages.

Symbol	Parameter
	IPv4
	IPv6

Tab. 29: Select the protocol version

### IPv4

- Click on the "IPv4" symbol.  
A list of general information about the IPv4 settings will be displayed.
- Page through the list using the "Up" and "Down" arrows.

Parameter	Setting
DHCP	off/on
IP address	xxx.xxx.xxx.xxx
Network mask	xxx.xxx.xxx.xxx
Router address	xxx.xxx.xxx.xxx

Tab. 30: IPv4 settings

### IPv6

- Click on the "IPv6" symbol.  
A list of general information about the IPv6 settings will be displayed.
- Page through the list using the "Up" and "Down" arrows.
- Click on the desired entries to display the IPv6 addresses.

Parameter	Setting
DHCP	off/on

Tab. 31: IPv6 settings



Parameter	Setting
IP address 1	...
IP address 2	...
Auto address	...
Link-local addr.	...

Tab. 31: IPv6 settings

#### 7.4.4 Alarm relays

There are two floating relay outputs in the connection box on the rear of the unit, which may be used to output system messages from the chiller to an external signal source (see section 5.6.2 "Connecting the alarm relay query device"). The relay outputs may be configured here.

- Click on the "Alarm relay" symbol to display a list of lower-level screen pages.

Symbol	Parameter
	Switch NO/NC Switch the alarm relay as a normally closed or normally open contact.
	Function list Allocation of a function to the respective alarm relay.

Tab. 32: "Alarm relay" zone





Note:

For the factory setting of alarm relay allocation see section 9.1 "List of system messages" (tab. 36).

#### Switch NO/NC

The switch logic of the relay output, i.e. whether it is to be used as a normally closed or normally open contact, may be set here.

- Click on the "Switch NO/NC" symbol.
- Choose your preferred switch logic by selecting it from the display.
- Confirm your entry with "OK".

Symbol	Parameter
	Normally Open Switch the alarm relay as a normally open contact.
	Normally Closed Switch the alarm relay as a normally closed contact.

Tab. 33: Switch logic of the alarm relay





Note:

The factory setting of the relay outputs in their de-energised state is NO (Normally Open).

#### Function list

This is where you specify which error messages should lead to switching of the respective relay output.

- Click on the "Relay 1" or "Relay 2" symbol, and select the alarm relay to which you wish to assign a function.
- From the list of errors, select the function which should cause the previously selected relay output to switch.
- If applicable, assign further functions to the relay output, and the output will then be switch if **at least one** of the assigned functions leads to an error message.
- Confirm your entry with "OK".
- If applicable, configure the other relay output with other functions.

Symbol	Parameter
	Assign relay 1
	Assign relay 2

Tab. 34: Function list

#### 7.4.5 Language settings

All displays on the unit are available in 21 different languages.

- Click on the "Display language" symbol.
  - Page through to the required language using the "Up" and "Down" arrows.
  - Confirm the chosen language with "OK".
- The language will change over immediately, and all menu displays will appear in the chosen language.

#### 7.4.6 Self-test

In the event of a malfunction in the unit which fails to produce an error message, it may be useful to check the key functions of all components with a self-test. You may continue to operate the unit as normal while the self-test is being carried out.

- Click on the "Self-test" symbol.
  - Confirm the start of the self-test with "OK".
- While the self-test is being carried out, a progress indicator will appear on the display. Once the test is complete, either the message "Unit OK" or "Check error" will be displayed.
- If applicable, use the error list to determine which malfunction applies.

# 8 Inspection and maintenance

EN

## 7.5 System messages

We distinguish between three different types of system messages on the unit:

- Malfunctions ⚠
- Errors ⚠
- Servicing 🔧

If a corresponding message applies, the "System messages" symbol is displayed in the menu bar (fig. 23, item 13). A list of all possible system messages may be found in section 9.1 "List of system messages".

Click on the "System messages" symbol.

A list of all active system messages will be displayed. The individual messages are arranged in ascending order as they occur according to the above three categories.

If an error message can only be resolved by the Rittal Service team, the "Service" symbol (S) will additionally appear after the error message.

- In such cases, please contact Rittal Service (see section 9 "Troubleshooting").

### 7.5.1 Occurrence of a malfunction

In the event of a malfunction, the start screen will be superimposed with an error message.

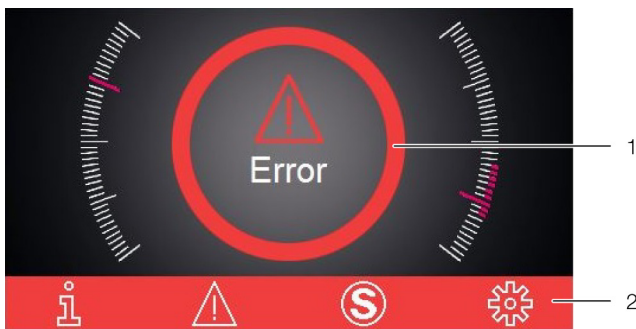

Fig. 26: Screen in the event of a malfunction

#### Key

- 1 Superimposed
- 2 Menu bar in red

The start screen is superimposed with this message in the event of a device malfunction:

If the malfunctions cannot be resolved by the operator himself, the Service symbol will additionally be displayed (fig. 23, item 14).

- Contact the Rittal Service team if you are unable to resolve the malfunction yourself (see section 9 "Troubleshooting").

### 7.5.2 Display in case of errors

If errors have occurred or servicing is required, the "System messages" symbol will appear in the menu bar (see section 7.5 "System messages").

Most system messages are reset automatically once the fault has been resolved.

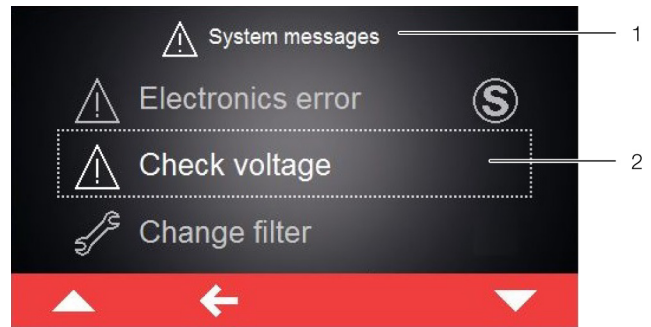

Fig. 27: Screen showing error messages

#### Key

- 1 "Errors" menu
- 2 Error message

If an error message applies that cannot be resolved by the operator himself and which is not reset automatically, the "Service" symbol will appear after the error message and in the control bar next to the symbol for system messages (fig. 28, item 2).

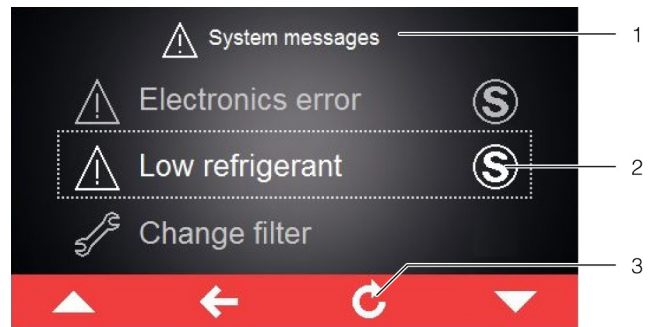

Fig. 28: Screen showing error messages

#### Key

- 1 "Errors" menu
- 2 Error message
- 3 "Return" button

- Contact Rittal Service (see section 9 "Troubleshooting").
- Acknowledge the error message by pressing the "Return" button.

## 8 Inspection and maintenance

Proper, regular inspections and maintenance (once a year is recommended) and usage of original spare parts only are crucial for problem-free operation and a long service life of the chiller.

We therefore recommend a maintenance contract.

We offer maintenance service.

Our service contact:

Phone: +49 2772 505-1855

Fax: +49 2772 505-1850

E-mail: [service@rittal.de](mailto:service@rittal.de)





**Danger!**  
**Risk of electric shock at live connections!**  
**Prior to any inspection and maintenance work, the chiller must be disconnected from the power supply.**  
**When the master switch is switched off, the alarm relay is still live. Disconnect signal connector X2 as well.**



**Caution!**  
**Never use flammable liquids for cleaning.**

### Overview of the inspection and maintenance tasks

Assembly	Task	Interval
Cooling medium level	Check for sufficient filling, top up if necessary.	When indicated on the display or via the alarm relay contact
Filter mat (accessory)	Clean or replace filter mat.	4 weeks or depending on the level of contamination
Cooling medium	Check cooling medium circuit for soiling and any foreign bodies (chips and the like). Check mix ratio.	4 weeks
Tank, components, and all connections (piping, valves and fittings, hoses) in the circuit for the equipment to be cooled	Check for leaks.	4 weeks
Condenser (air-cooled)	Clean fins using compressed air, or with a brush.	3 months
Condenser fan (air-cooled)	Check noise generation, clean.	6 months
Cooling medium	Replace cooling medium.	1 year
Condenser (water-cooled)	Check for adequate flow rate.	1 year

Tab. 35: Inspection and maintenance tasks

## 8.1 Maintaining the refrigerant circuit



Note:

The refrigerant circuit is filled with a comparatively small quantity of refrigerant (< 3.5 kg). This means that maintenance to the cooling circuit (such as regular leak checks) is not generally needed.

As a hermetically sealed system, the refrigerant circuit has been filled in the factory with the required amount of refrigerant, tested for leaks and subjected to a function test run.

Maintenance tasks on the refrigerant circuit are only allowed to be undertaken by a specialist refrigeration company. We recommend a maintenance contract that includes an annual inspection of the refrigerant circuit (European regulation EC no. 517/2014 / fluorinated greenhouse gases).

## 8.2 Monitoring the cooling medium

The fill level of the cooling medium tank is monitored with a level switch. If the fill level drops below the lower limit, a corresponding message will appear on the display (see section 9.1 "List of system messages").

- Top up with cooling medium as soon as possible if indicated by a message on the display.
- Regularly check the quality of the cooling medium, and if necessary, improve it as described under section 6.1.3 "Preparation and care" beschrieben.
- Regularly measure the glycol content with the aid of a refractometer (fig. 29). If you have any questions about this, please contact our service department.
- In order to prevent the formation of fungus and algae, the cooling medium should be replaced at least once a year. The use of pure water may also cause the formation of fungus or algae.

If the chiller is used under certain physical conditions ( $T_w < 10^\circ\text{C}$ ), condensation may form in the system. This can be minimised by means of suitable insulation or the optionally available room-temperature-based control.



Fig. 29: Refractometer

# 8 Inspection and maintenance

EN



**Note:**

The manufacturer's guarantee and liability will be rendered void in cases of incorrect use and treatment of the chiller. To prevent problems in the cooling medium circuit (including water-cooled chillers), it is imperative that the VGB Cooling Water Guidelines (VGB-R 455 P) are observed.

### 8.3 Cleaning the condenser

To ensure the correct function of the chiller, the fins on the air-cooled condenser must be kept clean. It must be cleaned at regular intervals of at least every three months; the frequency of cleaning depends on the degree of soiling in the rooms where the unit is installed. Ambient air containing oil in conjunction with dust will result in increased soiling of the condenser fins. In such cases, thorough cleaning with compressed air is only possible under certain circumstances. In such cases, the additional use of a metal filter mat is required (see section 11.4 "Metal filter (aluminium filter)").

When cleaning, it is imperative to observe the following warning and safety notes below.



**Danger!**

**Prior to any inspection and maintenance work, the chiller must be disconnected from the power supply at the master switch.**



**Danger!**

**Temperatures of up to 60°C may occur inside the chiller. Wait approx. 10 min. after you have switched off the chiller to allow the pipe to cool down.**



**Risk of cuts!**

**Sharp-edged condenser fins! Use gloves as personal protection equipment.**



**Caution!**

**Risk of damage for the condenser fins due to powerful compressed air! Use the compressed air carefully to avoid damage.**

When cleaning, please proceed as follows:

- Electrically isolate the chiller at the master switch.
- Secure the master switch to prevent it being switched back on.
- Remove the chiller cover by pulling upwards.

- Raise the side covers of the chiller slightly with the handles and remove them.

This will give you access to the condenser at the centre of the chiller.

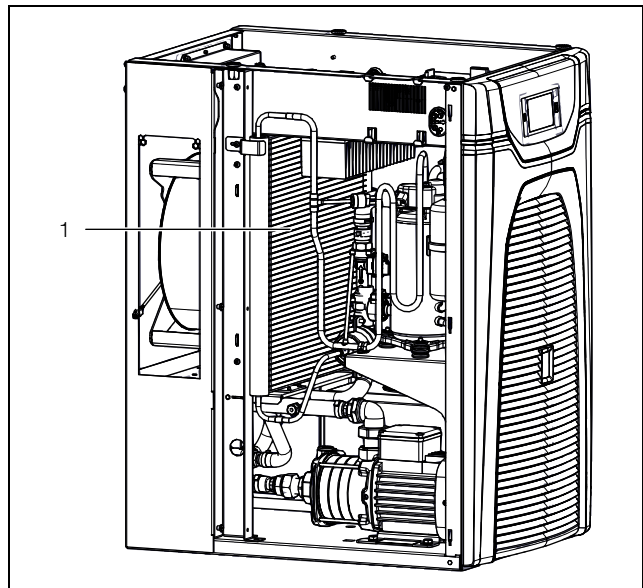

Fig. 30: Cleaning the condenser (shown here: 3334300)

**Key**

- 1 Condenser

- Use compressed air or a vacuum cleaner with the brush attachment to clean the condenser.

### 8.4 Cleaning the filter mat (accessories)

Metal filter mats may be washed with water or grease-dissolving detergents. Textile filter mats and the pleated filter in front of the inverter housing must be replaced at regular intervals (see section 5.7 "Installing the filter mats (accessories)").

- At the front of the chiller, pull the louvred grille away from the mounting clips, and place or lay it down somewhere safe.
- Remove the filter mat in front of the air intake grille on the chiller.
- Clean the metal filter mats e.g. using water and degreaser/detergent.
- Place the cleaned metal filter mat or a new textile filter mat in front of the air intake grille on the chiller.
- Press the louvred grilles back onto the mounting clips.
- Replace the pleated filter in front of the inverter housing accordingly.

### 8.5 Draining the cooling medium tank

- Drain the cooling medium tank via the tank drain nozzle (fig. 2, item 7) either directly or using a hose into a container.
- When disposing of the cooling medium, observe the locally application regulations on water pollution.



## 9 Troubleshooting

In operation, the chiller operates in a safe state. The chiller maintains the cooling medium inlet temperature at the setpoint set.

Possible causes for deviation from the setpoint could be:

- Cooling demand too high
- Ambient temperature too high
- Failure to observe required distances
- Clogged evaporator coil
- Flow rate too low or too high
- Soiled condenser
- Lack of refrigerant
- Level of cooling medium in tank too low
- Cooling medium temperature set too low
- Parameters set incorrectly

The malfunctions are only allowed to be rectified by suitably instructed, qualified personnel.

For information on malfunction analysis, refer to tab. 36 "Error messages" or contact our service department:

### **Service contact:**

Rittal International Service  
Auf dem Stützelberg  
35745 Herborn

Phone: +49 2772 505-1855

Fax: +49 2772 505-1850

E-mail: [service@rittal.de](mailto:service@rittal.de)











# 9 Troubleshooting

EN













## 9.1 List of system messages

The applicable error messages are displayed with the corresponding symbol in the Errors list (see section 7.5 "System messages"). Extended information for resolving individual faults may be found in this section.

Contact details for the Rittal Service team can be found in section 9 "Troubleshooting".









System message	Alarm relay output (factory setting)	Troubleshooting measures/solutions
Med.temp. too high 	–	The measured medium temperature (water outlet) is above the set alarm limit for your chiller. Please check any maintenance and error messages, and check the design of your cooling unit. For any further questions, please contact Rittal Service directly.
Med.temp. too low 	–	The measured medium temperature (water outlet) is below the set alarm limit for your chiller. Please check any maintenance and error messages, and check the design of your cooling unit. For any further questions, please contact Rittal Service directly.
Change filter 	–	The filter mat in your chiller is dirty. Please replace or clean the filter mat and confirm this by pressing reset in the list of system messages on the chiller display.
Clean condenser 	–	The condenser in your chiller is dirty. Please remove the roof plate and side panels and clean the heat exchanger, e.g. using compressed air. The error message will terminate automatically approximately 30 seconds after it has been resolved.
Air routing 	1	The air inlet or outlet is blocked. Please remove the blockage and ensure that minimum distances from the air inlet or outlet to components inside the enclosure are observed.
Exp. valve defect 	2	The electronic expansion valve in your chiller is reporting a malfunction. Please contact your Rittal Service.
Ext.temp. range 	1	Your chiller is being operated outside of the admissible ambient temperature. Please ensure that the ambient temperature does not exceed the admissible range
Low refrigerant 	2	Your chiller is reporting a lack of refrigerant in the active cooling circuit. Please contact your Rittal Service.
Fan alarm 1 	2	The fan in your chiller is blocked. Please check if you can see a blockage and remove it. If no blockage is visible, please replace the fan. You may order the required spare part directly from Rittal.
Fan alarm 2 	2	The fan in your chiller is defective. Please replace the fan. You may order the required spare part directly from Rittal.

Tab. 36: Error messages

System message	Alarm relay output (factory setting)	Troubleshooting measures/solutions
Inverter cooling 	–	The inverter heat sink in your chiller is dirty. Please remove the roof plate and side panels and clean the heat sink, e.g. using compressed air. The error message will terminate automatically approximately 30 seconds after it has been resolved.
Compressor defect 	2	The compressor in your chiller is reporting a malfunction. Please contact your Rittal Service.
Sens. xx defect 	2	Sensor xx in your cooling unit is reporting a sensor failure. Please contact your Rittal Service.
Ext.sens.xx miss. 	1	The external sensor xx is not connected or has a malfunction. Please check the connection or select another control mode.
Check voltage 	2	You are operating your cooling unit outside of the admissible voltage ranges. Please check the power supply to the cooling unit and observe the specifications on the rating plate.
Electronics error 	2	The electronics in your cooling unit are reporting an electronic fault. Please contact your Rittal Service.
Check parameters 	–	Due to an error, the chiller has been reset to the factory defaults. Please check the current messages or contact your Rittal Service team.
Inverter error 	2	The inverter in your chiller is reporting a malfunction. Please contact your Rittal Service.
Compressor phase 	2	The compressor in your chiller is reporting a malfunction. Please contact your Rittal Service.
Overload 	1	Please check the rating of your chiller. For any further questions, please contact your Rittal Service team directly.
Alarm act.cooling 	–	The active cooling function of your unit is defective. Please contact your Rittal Service.
Pump error 	2	The motor circuit-breaker on the pump has tripped. Please contact your Rittal Service.

Tab. 36: Error messages

# 10 Decommissioning and disposal

System message	Alarm relay output (factory setting)	Troubleshooting measures/solutions
Warning icing 	–	The evaporation temperature is too low. This may be because the flow rate is inadequate or the setpoint is too low.
Alarm icing 	2	The evaporation temperature is often or permanently too low. Please contact your Rittal Service.
Warn. tank level 	1	The fill level of the tank is low and needs to be topped up.
CoolWatrSuppLow 	–	Please check the cooling water supply to your unit.
Heating error 	1	The integral safety thermostat in the heater has tripped. Please check the fill level in the water tank. If this message occurs repeatedly, please contact your Rittal Service team.
Error free cool. 	–	Malfunction in the free cooling valve. Please check the valve for smooth running or contact your Rittal Service team.
Flow warning 	1	The flow rate is lower than the set warning threshold value. Please check the hydraulic circuit, water filter and tank fill level.
Flow alarm 	2	The flow rate is lower than the alarm threshold value. Please check the hydraulic circuit, water filter and tank fill level. If this message occurs repeatedly, please contact your Rittal Service team.

Tab. 36: Error messages

## 10 Decommissioning and disposal

The chiller is only allowed to be shut down by authorised, qualified personnel. For this purpose the chiller must be decommissioned.

### 10.1 Decommissioning

If the chiller is not to be used for an extended period (more than 6 months) the cooling medium circuit must be drained. This will prevent the evaporation of water, and the water-glycol ratio of the cooling medium will not be altered. If the glycol thickens, the cooling medium pump seal may be irreparably damaged.

- Electrically isolate the chiller at the master switch.
- Secure the master switch to prevent it being switched back on.
- In the connection box, disconnect all electrical connections to the chiller (mains connector, signal connector and IoT interface).

- Drain the cooling medium tank via the tank drain nozzle (fig. 2, item 7), either directly or using a hose, into a container.
- For disposal of the cooling medium, observe the applicable regulations on water pollution.
- Disconnect and dismantle the cooling medium circuit connections.
- To recommission the chiller, proceed as described in section 6 "Commissioning". Make the same checks as described in that section.

### 10.2 Disposal



**Caution!**

**Risk for the environment! Intentional release of the refrigerant is strictly prohibited. Refrigerant must be disposed of properly.**

- Decommission the chiller (see section 10.1 "Decommissioning").
- Notify your supplier or our service department for proper disposal of the chiller.

**Certificate in accordance with BGR 500 chap. 2.35 and DIN EN 378-2 on the inspection of a cooling system**



Note:  
If a system is changed or taken out of operation for more than 2 years, it is to be re-inspected and a new certificate issued. A system has been modified:

- if a system is opened and converted to a different refrigerant,
- if stationary system is moved elsewhere,
- if an existing system is extended or converted
- or major improvements are carried out.

**11 Accessories**

**11.1 Connection set for air/water heat exchangers**



Note:  
The connection set can only be used with the 2.5 kW chiller (Model No. 3320200).

The connection set is used to ensure professional laying of water connections between chiller and air/water exchanger. The pressure hoses (L = 3.60 m) may be cut to length individually, depending on the application.

Supply includes:

- Hose for water return
- Hose for water inlet including regulator valve for regulating the volumetric flow (setting range 3 to 12 l/min)
- Assembly parts



Fig. 31: Connection set

Material	Packs of	Model No.
Water-carrying parts EPDM/brass	1	3201990

Tab. 37: Connection set for air/water heat exchangers

**11.2 Flow regulator valve**



Note:  
The flow regulator valve can only be used with the 2.5 kW chiller (Model No. 3320200).

For use with air/water heat exchangers, especially if more than one heat exchanger (n > 1) is used in the water cooling circuit. The correctly set valve then ensures the same quantity of cooling medium for all equipment. The valve is used for hydraulic balancing.

- Material: Brass
- Setting range: 3 – 12 l/min



Fig. 32: Flow regulator valve

Version	Packs of	Model No.
G 3/4" x Rp 1/2" for volumetric flow control	1	3301930
G 3/4" x Rp 1/2" for volumetric flow control	1	3301940

Tab. 38: Flow regulator valve

**11.3 Textile filter mats**

For dry, coarse dust and lint in the ambient air, we recommend installing an additional PU foam filter mat in the chiller.

Depending on the incidence of dust, you will need to replace the filter mat from time to time (see section 8.4 "Cleaning the filter mat (accessories)").

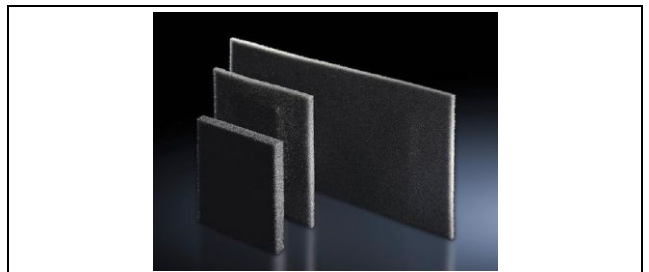

Fig. 33: Textile filter mats

Chiller	Packs of	Model No.
3320200/3334300	1	3285920
3334400	1	3285900

Tab. 39: Textile filter mats

# 11 Accessories

EN

A separate filter mat for the inverter housing is available as an accessory.

Chiller	Packs of	Model No.
3320200/3334300/3334400	1	3285940

Tab. 40: Pleated filter, inverter housing

## 11.4 Metal filter (aluminium filter)

Particularly when chiller units are used in dusty and oil-laden environments, it is advisable to use washable metal filters. If air or steam condenses on the metal surfaces, any particles that may be present will adhere to the metal and are easily washed out with water or grease-dissolving detergents.

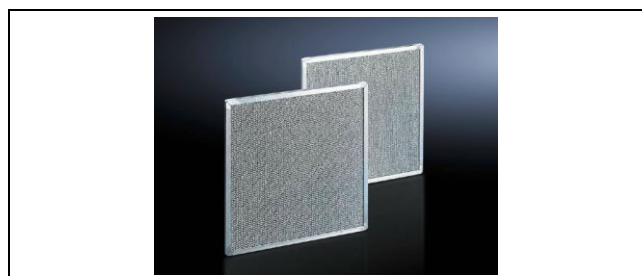

Fig. 34: Metal filters

Chiller	Packs of	Model No.
3320200/3334300	1	3285930
3334400	1	3285910

Tab. 41: Metal filters

## 11.5 Cooling medium for chillers (ready-mix)

Chiller systems are only suitable for the cooling of a water/glycol mixture. As well as protecting against frost, this cooling medium also serves to inhibit bacterial growth and provide optimum corrosion protection.



Fig. 35: Cooling medium for chillers (ready-mix)

Mixing ratio	Content	Model No.
1:4 (indoor)	10 l	3301960
	25 l	3301965
1:4 (outdoor)	10 l	3301950
	25 l	3301955

Tab. 42: Cooling medium for chillers (ready-mix)

## 11.6 Levelling feet

To compensate for height differences with floor irregularities.



Fig. 36: Levelling feet

Version	Thread	Adjustment height	Model No.
Without hex socket	M12 x 40	18 – 43 mm	4612000
With hex socket	M12 x 60	18 – 63 mm	7493100

Tab. 43: Levelling feet

## 11.7 Twin castors

With the help of twin castors the chiller can be moved and thus used at different production locations.



Fig. 37: Twin castors

Mounting thread	Maximum admissible static load (per castor)	Model No.
M12 x 20	75 kg	6148000 (recommended)
M12 x 20	120 kg	7495000

Tab. 44: Twin castors

## 11.8 Cross member

Used as a base/plinth component and to improve the chiller's stability.



Fig. 38: Cross member

Height [mm]	For enclosure depth	Model No.
70	600/800	8601680

Tab. 45: Cross member

### 11.9 External temperature sensor

If the medium temperature needs to be controlled depending on the ambient temperature (positive or negative), differential-based control is used.

Connection length	Packs of	Model No.
2.5 m	1	3124400

Tab. 46: External temperature sensor

## 12 Appendix

### 12.1 Block diagram

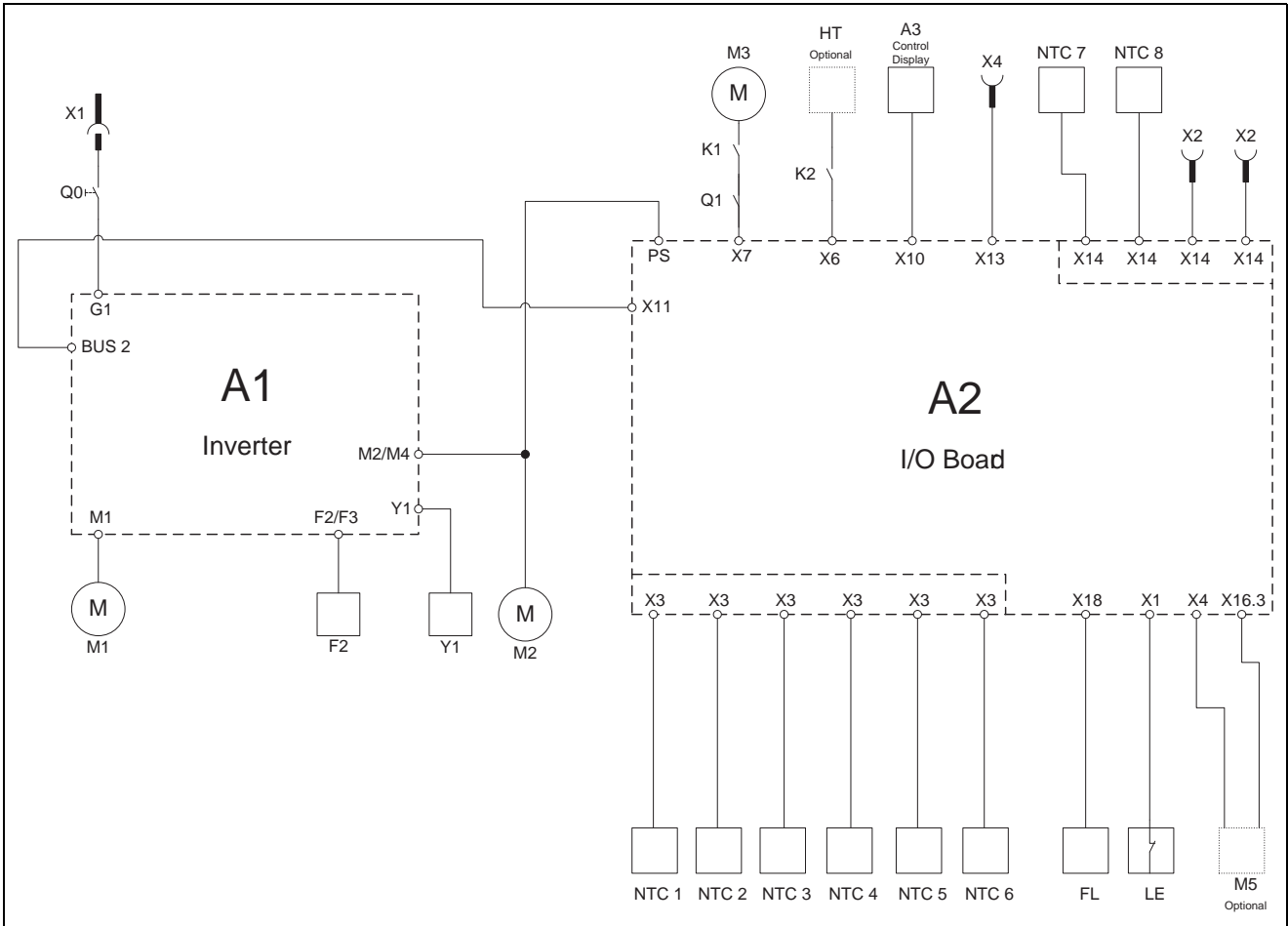

Fig. 39: Block diagram

**Key**

- A1 Inverter
- A2 I/O Board
- A3 Control Display
- F2/F3 High Pressure Switch
- FL Flow Sensor
- G1 AC In
- HT Heater
- K1 Contactor
- K2 Contactor
- LE Water Level Switch
- M1 Compressor
- M2 Condenser Fan
- M3 Pump
- M5 Freecooling Valve
- NTC1 Water Outlet Temperature
- NTC2 Water Inlet Temperature
- NTC3 Condensation Temperature
- NTC4 Evaporation Temperature
- NTC5 Compressor Suction Temperature
- NTC6 Ambient Temperature
- NTC7 External Sensors
- NTC8 External Sensors
- Q0 Main switch
- Q1 Motor protection switch
- X1 Power Supply

- X2 Alarm relay 1/2/remote on off
- X4 RJ45 BMS Input
- X14 Customer interface
- Y1 Electronic Expansion Valve



## 12.2 Spare parts

Spare parts may be ordered directly from the Rittal website.

– [http://www.rittal.com/com\\_en/spare\\_parts](http://www.rittal.com/com_en/spare_parts)

■ Select the Model Number of your chiller here, then click on "Show spare parts".



Note:

The components used are Rittal-specific components. We recommend using only original Rittal spare parts to ensure the guaranteed unit properties (output).

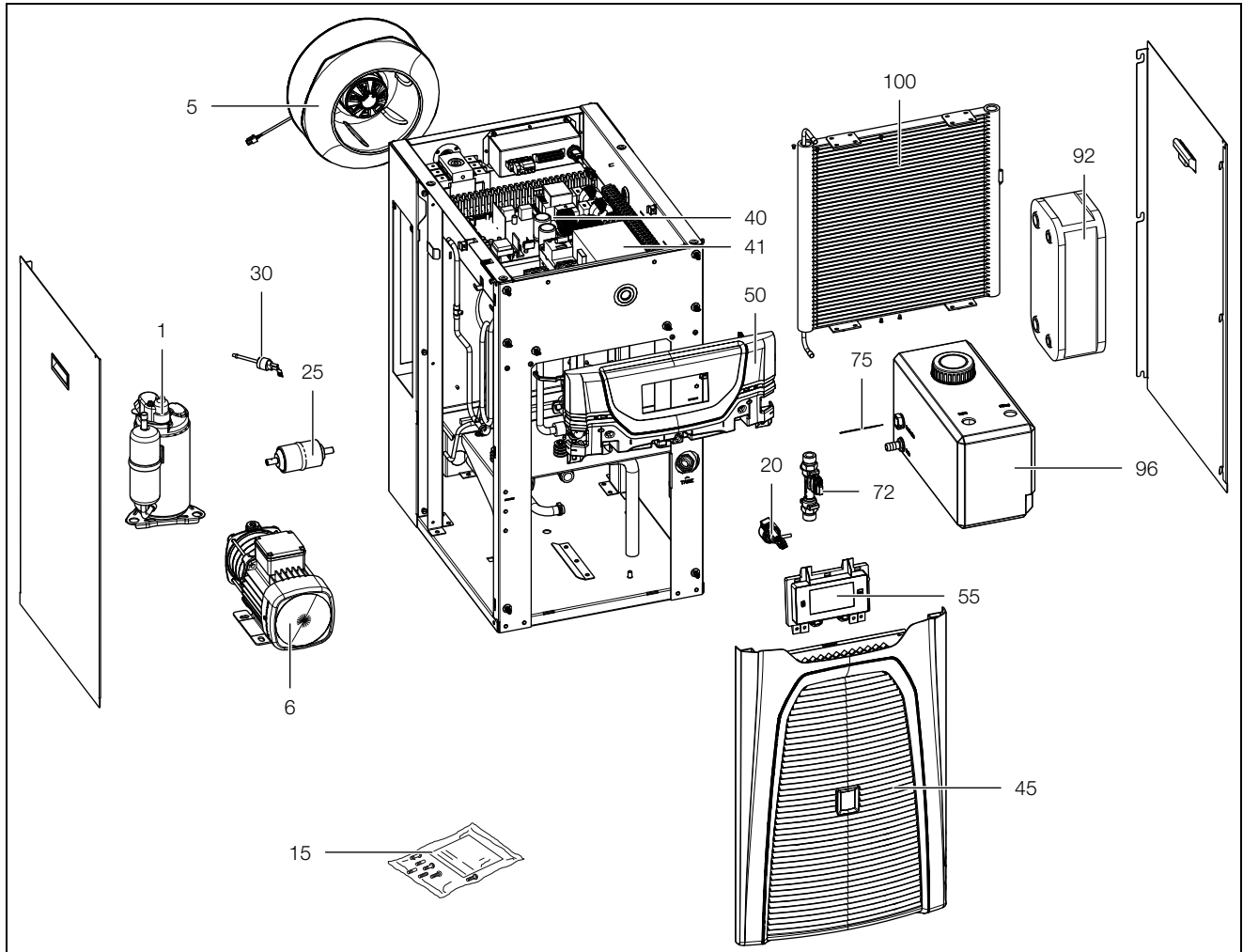

Fig. 40: Spare parts drawing

### Key

1	Compressor	96	Tank
5	Radial fan	100	Condenser
6	Cooling medium pump	102	Display cable (not illustrated)
15	Accessories bag		
20	Expansion valve		
25	Dryer		
30	HD switch		
40	Inverter		
41	I/O board		
45	Grille		
50	Cover		
55	Display		
70	Temperature sensor (not illustrated)		
71	Temperature sensor (not illustrated)		
72	Flow sensor		
75	Level switch		
92	Plate heat exchanger		

# 12 Appendix

EN

## 12.3 Technical specifications

Designation	Unit	Model No.		
		3320200	3334300	3334400
Rated voltage/Rated frequency	V/Hz	380...415, 3~, 50 440...480, 3~, 60		
Rated output 50 Hz/60 Hz	kW	1.38/1.57	2.49/2.72	2.49/2.72
Minimum circuit ampacity	A	15		
Input ampere range	A	2.17 A @ 380 V 1.95 A @ 480 V	3.95 A @ 380 V 3.47 A @ 480 V	3.97 A @ 380 V 3.47 A @ 480 V
Total cooling capacity at $T_w = 18^\circ\text{C}$ , $T_u = 35^\circ\text{C}$ , 50 Hz/60 Hz (to DIN EN 14511)	kW	2.5/2.4	4.0/3.9	5.5/5.4
EER at $T_w = 18^\circ\text{C}$ , $T_u = 35^\circ\text{C}$ , 50 Hz/60 Hz (excluding power consumption of pump)	kW	2.41/2.08	2.8/2.36	2.57/2.26
Rating of overcurrent protective device*	A	15		
Operating temperature range	$^\circ\text{C}$	-5...+50		
Operating temperature range of cooling medium	$^\circ\text{C}$	+5...+35		
Sound power level $L_p$	dB (A)	74	75	75
Refrigerant – Identification – Charge	– g	R134a 460	R134a 760	R134a 930
GWP	–	1430		
CO <sub>2</sub> e	t	0.66	1.09	1.33
Permissible pressure, cooling circuit (PS)	MPa	HP 2.5 LP 1.6		
Permissible pressure, fluid circuit (PS)	MPa	0.0 (open circuit)		
IP Code		IP 24		
Tank volume	l	12		
Flow rate	l/min.	7	15	15
Fluid pressure range, 50 Hz/60 Hz	bar	1.6...2.5/2.3...3.6	1.9...3.3/2.7...4.9	1.9...3.3/2.7...4.9
Water connections		2 x 3/4" internal thread		
Power consumption of cooling medium pump, 50 Hz/60 Hz	kW	0.25/0.43	0.43/0.74	0.43/0.74
Weight	kg	84	90	96

Tab. 47: Technical specifications

\* Time delay fuse type CCMR 15 A or UL listed circuit breaker (DIVQ/7) of type:

- 3RV2711-4AD10 by SIEMENS (E235044) rated 15 A,
- FAZ-C15/3-NA by EATON (E235139) Class curve C rated 15 A,
- FAZ-D15/3-NA by EATON Class curve D rated 15 A

12.4 Device drawings

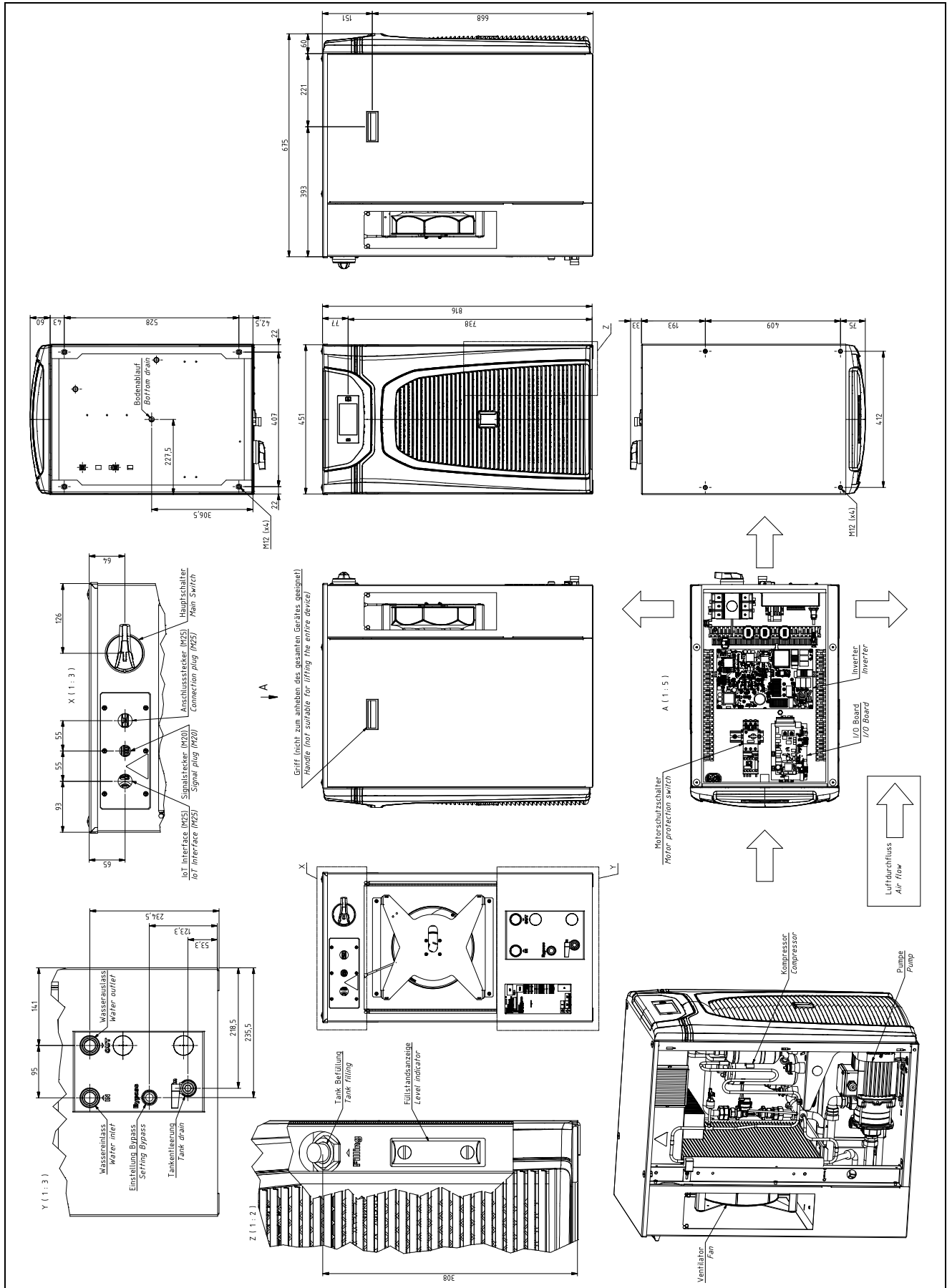

Fig. 41: 3320200

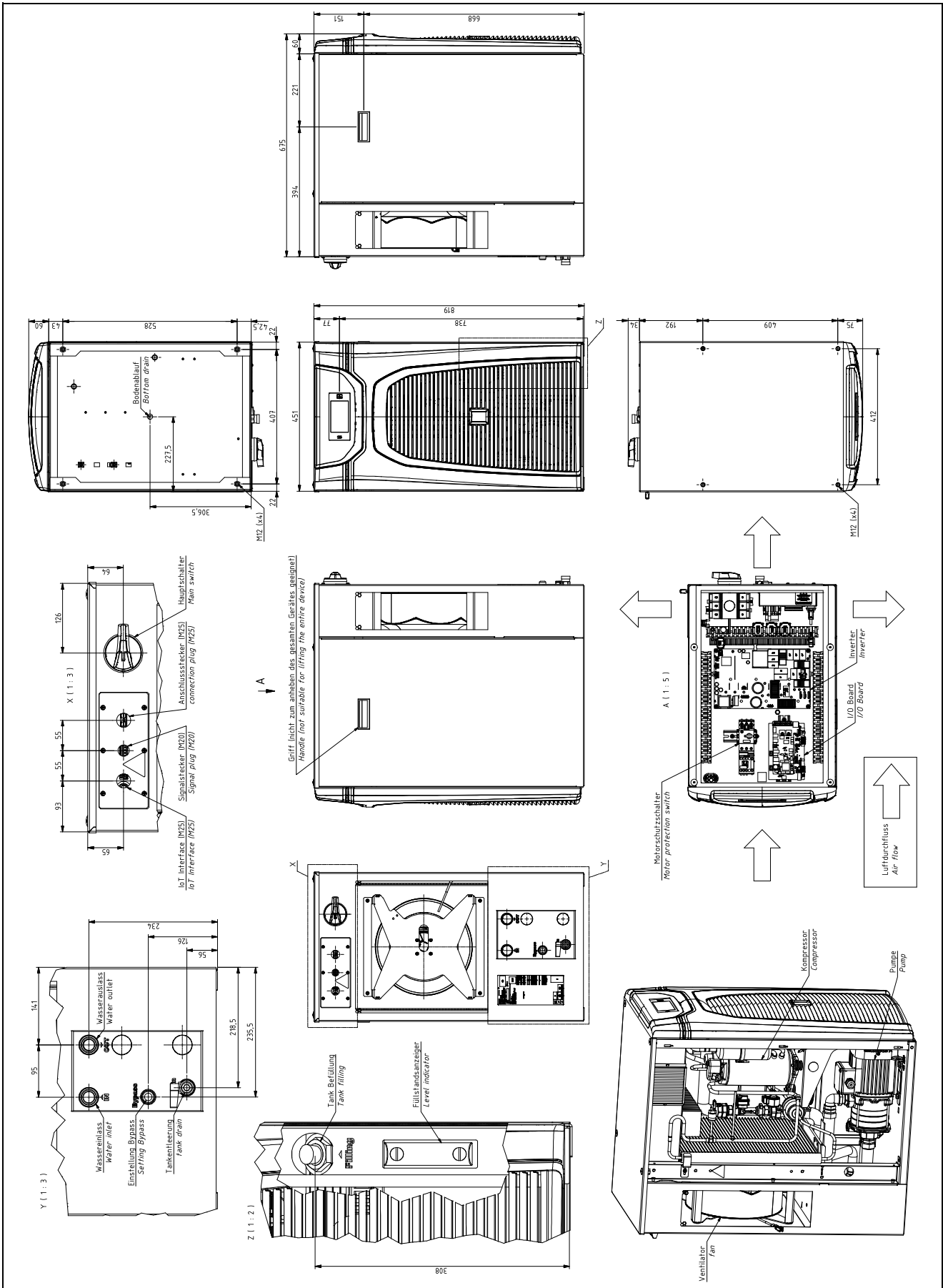

Fig. 42: 3334300

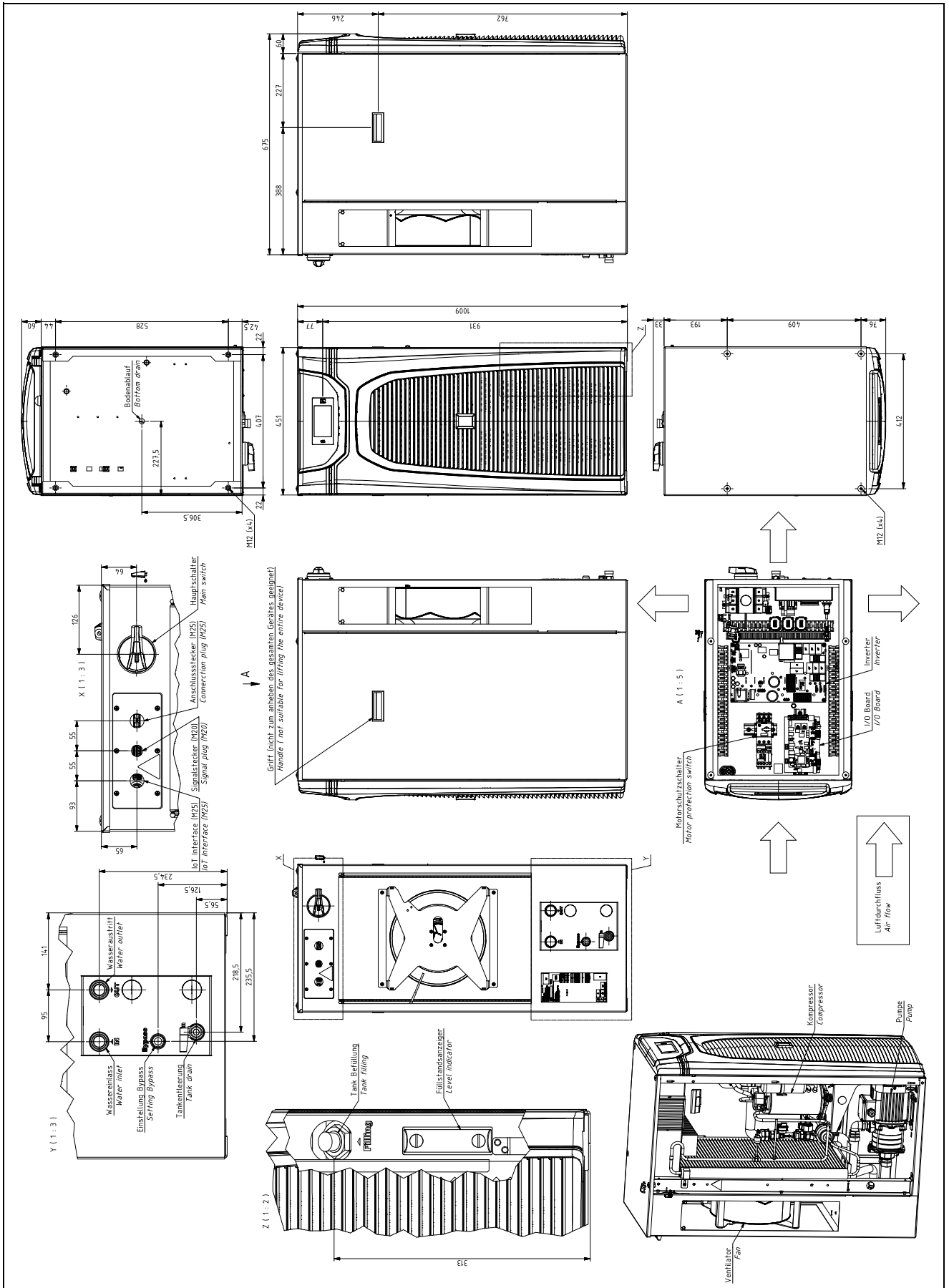

Fig. 43: 3334400

## 12.5 Operation of inverter pump

CRE, CRIE, CRNE, CRKE,  
SPKE, MTRE, CHIE, CME

**1 Control panel** Setpoint  
Sollwert

**Bedientastatur**

**2 Operating indications**  
**Betriebsanzeige**

	Stop	Supply off/Netz aus
	OK	Running/Läuft
	Stop	OK Set to stop/Ausgeschaltet
	Stop	Fault/Störung
		Running/Läuft
	Stop	Set to stop/Ausgeschaltet

/ Flashes/Blinkt

+ See Installation and Operating Instructions  
Siehe Montage- und Betriebsanleitung

**3 Setpoint setting**  
**Sollwert-einstellung**

**4 Max. or min. curve**  
**MAX- oder MIN-Kennlinie**

**5 Start Einschalten**

Min. 5 sec.

**6 Stop Ausschalten**

Min. 5 sec.

96405681 0608

## 12.6 Declaration of Conformity

## Vereinfachte EU-Konformitätserklärung / Simplified EU Declaration of Conformity



Wir, / We,

**Rittal GmbH & Co. KG • Auf dem Stützelberg • 35745 Herborn**

Erklären, dass die Produkte / declare that the products

**Flüssigkeitskühlsatz Blue e+ Chiller  
Blue e+ chiller for cooling media**

SK 3320200, SK 3334300, SK 3334400

folgenden Richtlinien entsprechen:  
conform to the following directives:

**Maschinenrichtlinie 2006/42/EG - Machinery Directive 2006/42/EC**

**EMV-Richtlinie 2014/30/EU - EMC Directive 2014/30/EU**

Bei einer nicht mit uns abgestimmten Änderung des Produkts verliert diese EU-Konformitätserklärung ihre Gültigkeit. In case of any amendments to the assembly not explicitly agreed with us, this EU declaration of conformity shall be invalidated.

Die vollständige und unterschriebene EU-Konformitätserklärung erhalten Sie auf der Produktseite der Rittal Homepage [www.rittal.com](http://www.rittal.com). The complete and signed declaration of conformity can be obtained from the product site of the Rittal homepage [www.rittal.com](http://www.rittal.com)

SCHALTSCHRÄNKE

STROMVERTEILUNG

KLIMATISIERUNG

IT-INFRASTRUKTUR

SOFTWARE & SERVICE

FRIEDHELM LOH GROUP

Seite 1 von 1

# Rittal – The System.

---

**Faster – better – everywhere.**

- Enclosures
- Power Distribution
- Climate Control
- IT Infrastructure
- Software & Services

1st edition 02.2018 / ID no. 338311 / Doc. no. D-0000-00001358-00

You can find the contact details of all Rittal companies throughout the world here.



[www.rittal.com/contact](http://www.rittal.com/contact)

RITTAL GmbH & Co. KG  
Postfach 1662 · D-35726 Herborn  
Phone +49(0)2772 505-0 · Fax +49(0)2772 505-2319  
E-mail: [info@rittal.de](mailto:info@rittal.de) · [www.rittal.com](http://www.rittal.com)



ENCLOSURES

POWER DISTRIBUTION

CLIMATE CONTROL

IT INFRASTRUCTURE

SOFTWARE & SERVICES

FRIEDHELM LOH GROUP