

Distribución de corriente

Componentes del sistema Flat-PLS

Flat-PLS 60/100

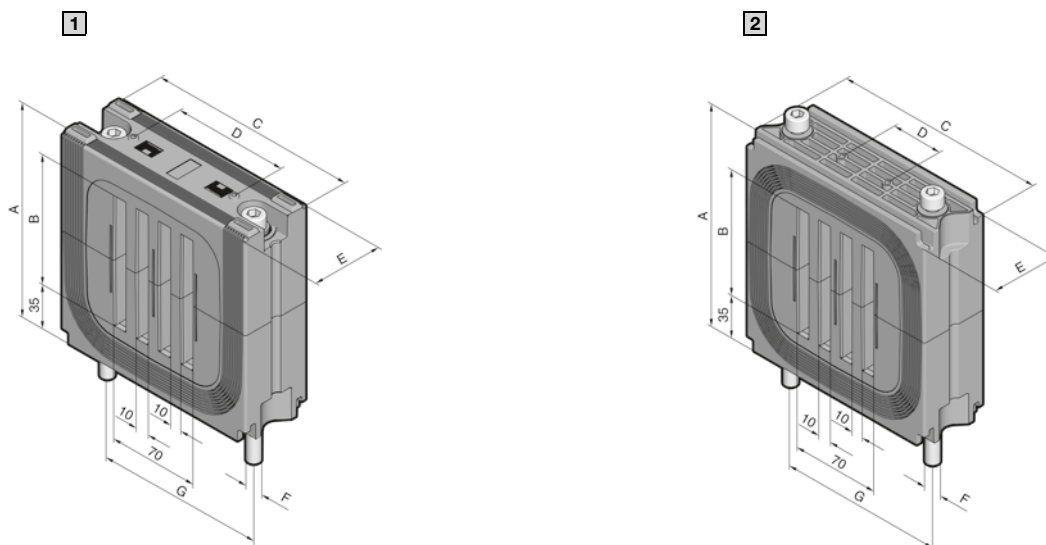

1 Soportes de barras Flat-PLS

Sistema	Para barras de hasta mm	A mm	B mm	C mm	D mm	E mm	F	Par de apriete	G mm	Ref. SV
Flat-PLS 60	4 x 60 x 10	127,5	60	120	70	50	M8	8 Nm	100	9676.002
Flat-PLS 100	4 x 100 x 10	162,5	100	165	90	55	M10	9 Nm	125	9676.004

2 Soportes de barras Flat-PLS para guía para estabilizadores

Sistema	Para barras de hasta mm	A mm	B mm	C mm	D mm	E mm	F	Par de apriete	G mm	Ref. SV
Flat-PLS 60	4 x 60 x 10	130	60	120	70	50	M8	10 Nm	100	9676.020
Flat-PLS 100	4 x 100 x 10	170	100	165	90	55	M10	12 Nm	125	9676.021

Flat-PLS 60/100

Garra para barras

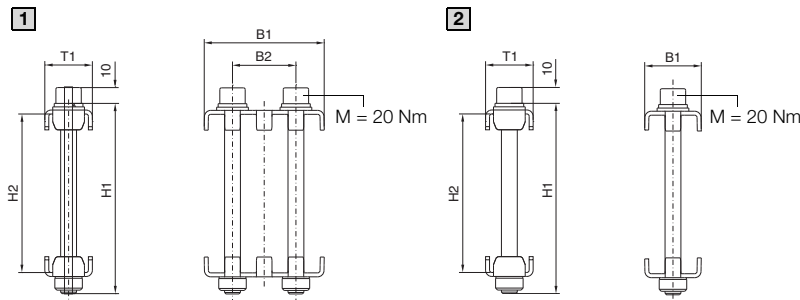

Ref. SV	B1 mm	B2 mm	H1	H2	T1 mm
9676.017 [2]	35,7	-	1)	+2/-3 ²⁾	30
9676.019 [1]	75,7	40	1)	+2/-3 ²⁾	30

1) Longitud del tornillo a solicitar por separado

2) En relación con el tornillo deseado $H2 = H1 - 20$ ($H1 \triangleq$ Longitud tornillo)

Perfil cubierta de cantos sin distancia

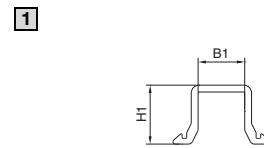

Ref. SV	B1 mm	H1 mm
9676.041 [1]	10,2	12,9

Piezas de contacto

A - A

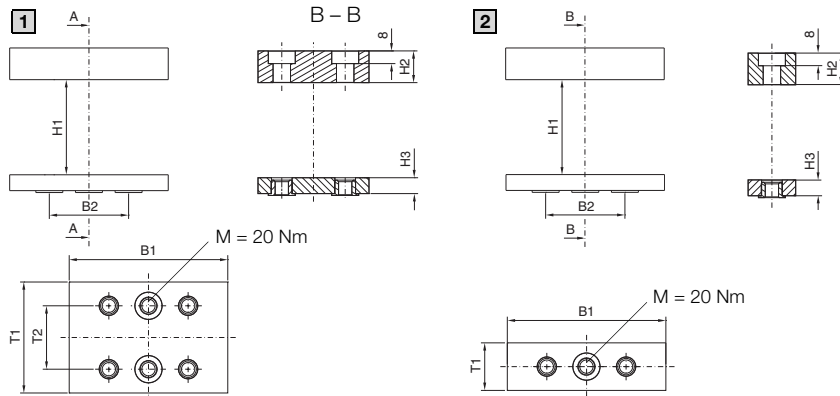

Ref. SV	B1 mm	B2 mm	H1 mm	H2 mm	H3 mm	T1 mm	T2 mm
9676.526 [2]	60	36	40 - 100	20	10	30	-
9676.546 [1]	60	36	40 - 100	20	10	70	40
9676.528 [2]	80	50	40 - 100	20	10	30	-
9676.548 [1]	80	50	40 - 100	20	10	70	40
9676.520 [2]	100	50	40 - 100	20	10	30	-
9676.540 [1]	100	50	40 - 100	20	10	70	40

Perfil cubierta de cantos con distancia

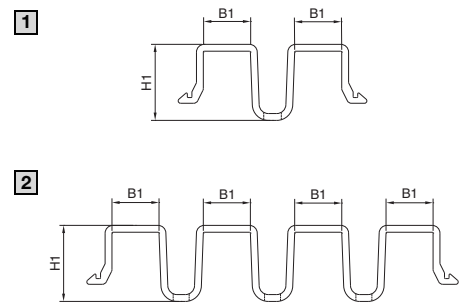

Ref. SV	B1 mm	H1 mm
9676.052 [1]	10,3	16,6
9676.054 [2]	10,3	16,6

Conectores horizontales

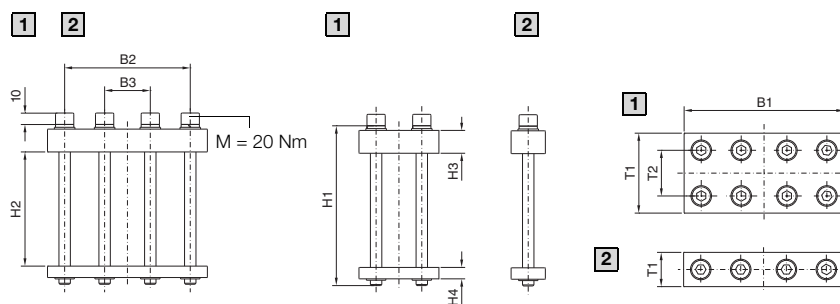

Ref. SV	B1 mm	B2 mm	B3 mm	H1 mm	H2 mm	H3 mm	H4 mm	T1 mm	T2 mm
9676.621 [2]	140	110	40	1)	H1 - 40	20	10	30	-
9676.641 [1]	140	110	40	1)	H1 - 40	20	10	70	40

1) Longitud del tornillo a solicitar por separado

Perfil cubierta laterales

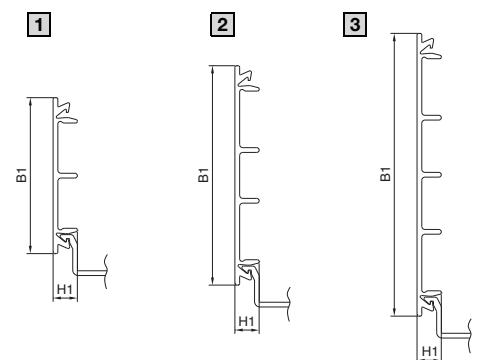

Ref. SV	B1 mm	H1 mm
9676.056 [1]	49,2	7,6
9676.058 [2]	69,2	7,6
9676.059 [3]	89,2	7,6

Distribución de corriente

Componentes del sistema Flat-PLS

Flat-PLS 60/100

Pletinas de conexión con bulón M12/M16

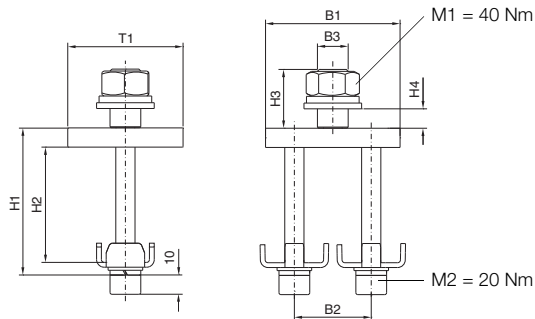

Ref. SV	B1 mm	B2 mm	B3 mm	H1	H2 mm	H3 mm	H4 mm	T1 mm
9676.700	70	40	M12	¹⁾	H1 - 21,5	30,6	15,6	60

¹⁾ Longitud del tornillo a solicitar por separado

Bornes de conexión directa

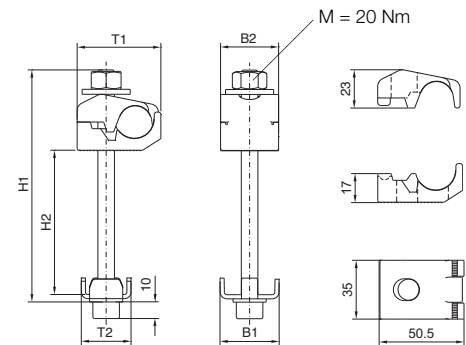

Ref. SV	B1 mm	B2 mm	H1	H2 mm	T1 mm	T2 mm
9676.730	35,7	35	¹⁾	H1 - 60	50,5	30

¹⁾ Longitud del tornillo a solicitar por separado

Pletinas de conexión con bulón M10

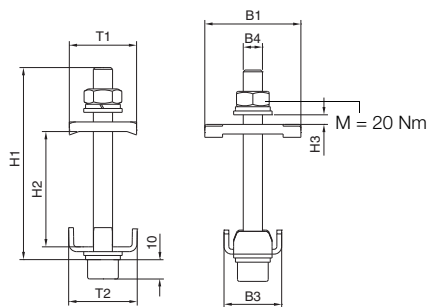

Ref. SV	B1 mm	B2 mm	B3 mm	B4 mm	B5 mm	H1	H2 mm	H3 mm	T1 mm	T2 mm
9676.710	50	-	30	M10	-	¹⁾	H1 - 40	5	35	35,7

¹⁾ Longitud del tornillo a solicitar por separado

Pletinas de conexión para pletinas flexibles

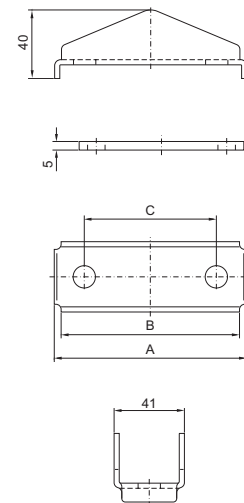

Ref. SV	A mm	B mm	C mm	Par de apriete
9676.747	81	73	46	20 Nm
9676.748	112	104	77	25 Nm
9676.749	149	141	114	30 Nm

Bloque de bornes de la barra de distribución

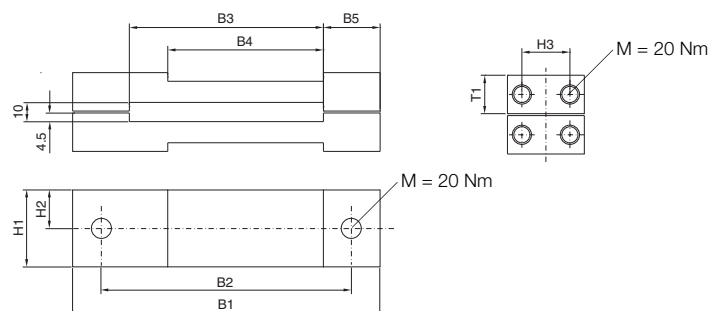

Ref. SV	B1 mm	B2 mm	B3 mm	B4 mm	B5 mm	H1 mm	H2 mm	H3 mm	T1 mm
9674.485	160	130	61	51	29,5	40	20	25	20
9674.488	160	130	101	81	29,5	40	20	25	20

Garra con tuerca encastada M10

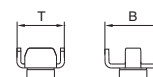

Ref. SV	B mm	T mm	Par de apriete
9676.832	37,5	30	20 Nm